

CONTENT

1 OVERVIEW	1
1.1 SAFETY REQUIREMENT AND CAUTIONS	2
1.2 SAFETY GUIDANCE	3
2 BEFORE USE	9
2.1 PURCHASE INSPECTION	9
2.2 NAMEPLATE	9
2.2.1 Nameplate Position and Content.....	9
2.2.2 Model Specification	10
2.2.3 AP100 parts description	11
2.3 AIR COMPRESSOR INTEGRATED MACHINE RATED OUTPUT CURRENT	11
2.4 PRODUCT SIZE	12
2.4.1 Wall-Mounted Shape and Installation Dimensions.....	12
2.4.2 Shape and Installation Dimension of Vertical Cabinet.....	13
2.5 MECHANICAL INSTALLATION	14
2.5.1 Installation space requirements.....	14
2.5.2 Disassembly and Installation of Cover Plate.....	15
2.6 ELECTRICAL INSTALLATION.....	16
2.6.1 Main circuit terminal.....	18
2.6.2 Control Terminal Defination	19
2.6.3 Selection of Dial Switch on Control Board and Functional Explanation of Its Corresponding Position.....	21
2.6.4 Control terminal wiring diagram.....	21
2.7 INDICATOR DESCRIPTION.....	22
3 HMI DISPLAY AND OPERATION	24
3.1 HMI BASIC OPERATION AND DISPLAY.....	24
3.1.1 Status Display	24
3.1.2 Running Parameters.....	25
3.1.3 Maintaining parameters:.....	26
3.1.4: Protection Parameters	28
3.1.6 Manufacturer parameter setting	31
3.1.7 Sensor Parameters.....	32
3.1.8 Inverter Debugging	34
3.2 MOTOR PARAMETERS	34
3.2.1 Fan Parameters	35
3.2.2 Fault Parameters.....	36
4. FUNCTIONAL PARAMETER TABLE	37

4.1 EXTERNAL KEYBOARD.....	37
4.2 MAIN ENGINE FUNCTION PARAMETER TABLE OF AIR COMPRESSOR	37
5 DEBUGGING GUIDANCE	70
5.1 INSTALLATION WIRING DIAGRAM.....	70
5.1.1 Main power cable	70
5.1.1 Control Terminal Cable.....	72
5.2 TOUCH SCREEN DEBUGGING CASE ANALYSIS	72
5.2.1 Frequency conversion debugging.....	73
5.2.2 Host motor parameter setting.....	73
5.2.3 Host motor trial run	74
5.2.4 Parameter setting of fan driver	75
6 . QUALITY ASSURANCE	76
6.1 WARRANTY PERIOD AND SCOPE	76
6.1.1 Warranty period.....	76
6.1.2 Guaranteed range	76
6.2 LIABILITY EXEMPTION	76
6.3 PRODUCT SCOPE.....	77

1 Overview

Thank you for purchasing the AP100 series air compressor integrated machine designed and manufactured by Suzhou VEICHI Electric Co., Ltd. This manual describes how to use this product correctly for good returns. Please read this manual carefully before using the product (installation, wiring, operation, maintenance, inspection, etc.). In addition, please use this product after fully understanding the safety precautions described in this manual.

AP100 series air compressor integrated machine adopts sheet metal structure, supports both floor-standing and wall-mounted installation methods, and is easy to install and debug. The control circuit terminals adopt pluggable plug-in terminals and are designed with error-proof insertion. High product integration, three-in-one design, including main unit, fan, motor cooling fan; built-in 220VAC AC power supply, transformer anti-overcurrent fuse, providing 24V external output; built-in integrated PT100, KTY84, PTC and other detection circuits and Protection circuit, etc. The product software uses special machine software. Communication with devices such as HMI and Internet of Things does not require debugging, enabling one-button activation.



1.1 Safety requirement and cautions

To ensure safe, reliable and reasonable use of this product, please use the product after fully understanding the safety precautions described in this manual.

1.1.1 Warning signs and meanings

This manual has used following signs which means there is an important part of security. While observing against the rules, there is a danger of injury even death or machine system damage.

	<p>Danger: Wrong operation may cause death or large accident.</p>
	<p>Caution: Wrong operation may cause minor wound.</p>

1.1.2 Warning signs position



Figure 1.1: Shell warning signs position



1.1.3Operational qualification

This product must be installed, wired, operated, maintained, etc. by trained personnel. The term “trained professionals” in this manual means that personnel working on this equipment must be trained in professional skills, familiar with the installation, wiring, operation and maintenance of the equipment, and properly respond to the various emergencies that arise during use. Happening.



1.2 Safety guidance

Safety rules and warning signs are provided for your safety. They are measures to prevent personal injury to the operator and damage to the product and associated systems. Please read this manual carefully before use and follow this manual carefully. Safety rules and warning signs operate. Safety rules and warning signs are divided into the following categories: general guidance, guidance for transportation and storage, instructions for installation wiring, instructions for operation, instructions for maintenance, and guidance for disassembly and disposal.



1.2.1General Guidance

	<ul style="list-style-type: none"> ●This product has a dangerous voltage and it controls a potentially dangerous sporting mechanism that, if not observed or not handled in accordance with the requirements of this manual, may result in personal injury or death, damage to the product and associated systems. ●Only trained personnel are allowed to operate this product, and before using this product, be familiar with all the safety instructions and operating instructions in this manual; correct operation and maintenance is a reliable guarantee for the safe and stable operation of this product. ●Do not perform wiring work with the power on. Otherwise, there is a danger of electric shock. In the wiring, inspection, maintenance, etc., please cut off the power of all related equipment and confirm that the DC voltage of the main circuit has dropped to safety. Level, wait 5 minutes before performing related work.
	<ul style="list-style-type: none"> ● Prevent children and the public from coming into contact with or close to the product. ● This product can only be used in accordance with the manufacturer's specified use. It may not be used in special fields such as emergency, rescue, shipbuilding, medical, aviation, nuclear facilities, etc. without permission. ● Unauthorized modifications and use of spare parts not sold or recommended by the manufacturer of this product may result in malfunction.
	<ul style="list-style-type: none"> ● Please be sure to deliver this manual to the actual user to ensure that the actual user can read this manual carefully before use. ● Before installing and debugging the drive, please read and fully understand these safety rules and warning signs.

1.2.2Guidance for transportation and storage.

	<ul style="list-style-type: none"> ● Correct transportation, storage, installation, and careful operation and maintenance are critical to the safe operation of the drive.
	<ul style="list-style-type: none"> ● Ensure that the drive is protected from shock and vibration during transportation and storage. It must also be stored in a dry, non-corrosive atmosphere, non-conductive dust and ambient temperature less than 60 °C.

1.2.3 Guidance for installation and wiring

	<ul style="list-style-type: none"> ● Only trained professionals should operate this product. ● The power cable, motor cable, and control cable must be tightly connected. The grounding terminal must be grounded reliably and the grounding resistance is less than 10Ω. ● Before turning on the drive panel, cut off the power of all associated devices and confirm that the DC voltage of the main circuit has dropped to a safe level. Wait 5 minutes before performing related operations. ● The static electricity of the human body may seriously damage the internal sensitive components. Before performing related work, please observe the measures and methods specified in the static electricity prevention measures (ESD), otherwise the drive may be damaged. ● Since the output voltage of the driver is a pulse waveform, if the output side is equipped with a capacitor for improving the power factor or a varistor for lightning protection, be sure to remove or modify it on the input side of the driver. ● Do not add switching devices such as circuit breakers and contactors on the output side of the driver. (If the switching device must be connected to the output side, the control must ensure that the output current of the driver is zero when the switch is activated).
	<ul style="list-style-type: none"> ● The power cable and motor cable specifications connected to the drive must meet the conditions shown in Table 3-7 3-8 of this manual.

1.2.4Operational guidance

	<ul style="list-style-type: none"> ● The drive is operated at high voltages and dangerous voltages are inevitably present on certain parts of the product. ● Regardless of where the fault occurs in the control device, it can cause major accidents or even personal injury, ie there are potentially dangerous faults; therefore,
---	--

	<p>additional external precautions or other means for ensuring safe operation must be taken, for example: Install independent current limiting switch, mechanical protection and other devices.</p> <ul style="list-style-type: none"> ● In order to ensure that the overload protection of the motor can operate correctly, the motor parameters of the input drive must be exactly the same as the actual motor used.
--	--

1.2.5 Maintenance Guidance

	<ul style="list-style-type: none"> ● The maintenance of this product can only be trained and authorized by the service department of Suzhou VEICHI Electric Co., Ltd., or the repair center, the professional engineer should be familiar with the safety warnings and operating instructions presented in this manual. ● Any defective device must be replaced in time. ● Before turning on the equipment for maintenance, be sure to disconnect the power supply and confirm that the DC voltage of the main circuit has dropped to a safe level. Wait 5 minutes before performing related operations.
---	---

1.2.6 Guidance on disassembly and waste disposal

	<ul style="list-style-type: none"> ● The drive box is reusable. Please keep the box for future use or return it to the manufacturer. ● The removed metal parts can be recycled and reused. ● Some devices may adversely affect the environment, such as electrolytic capacitors. Please dispose of such devices in accordance with the requirements of the environmental protection department.
---	--

Technical specifications

Table 1.1: Technical specification

Items		Specifications
Power input	Voltage, Frequency	Three phase 380V 50/60Hz
	Allowable fluctuation	Voltage: ±15%. Frequency: ±5%, aberration rate: as IEC61800-2
	Inrush current	Lower than rated current
	Efficiency	≥96%

Output	Output voltage	Output under rated condition: 3 phase, 0~input voltage, inaccuracy<5%
	Output frequency range	0~600.00Hz
	Output frequency accuracy	Max frequency ±0.5%.
	Overload capacity	133% rated current / 30MIN
Main control performance	Motor control mode	VC Without PG, V/F Control
	Modulation	Optimized SVPWM
	Carrier frequency	0.6~15.0kHz. Random carrier modulation
	Speed control range	VC With PG. Rated load 1: 100
	Steady speed accuracy	VC without PG: ≤1% rated Synchronous speed
	Frequency accuracy	Digital setting: Maximum frequency ×±0.01%. Analog setting: Maximum frequency×±0.2%
	Frequency resolution	Digital setting: 0.01Hz. Analog setting: max frequency×0.05%
	Torque boost	Auto torque upgrade 0.0%~100.0%; Manual torque upgrade 0.0%~25.0%
	Rated output voltage	Rely on power supply voltage compensate function, while motor rated voltage is 100%, set it at the range of 50-100%(output can not over input voltage).
	Auto-Volt adjustment	While power supply voltage fluctuates, it can auto-keep constant output voltage.
Auto energy-saving running	While under V/F control mode, according to load situation, auto-optimize output voltage to save energy.	

	Auto-limit current	Auto-limit the current while running to prevent over current break trouble.
	Instant power off treatment	While instant power off, realize continual operation by bus voltage control.
	Input signal	Motor temperature detection (Compatible PTC and KTY84). Oil temperature detection PT100. Pressure detection (4~20mA)
	External output signal	3 relay outpu, include load valve, oil pump start-stop switch, host cooling fan start and stop.
Protection function		Input/output phase loss protection, host over-current, over-load protection, Fan over-current, Motor cooling fan short-circuit protection, Over-heat protection, Preventing motor degaussing, etc..
Environment	Install place	Altitude ≤ 1000m,above 1000m down the rated amount, each increase of 100m down the rated amount of 1%;no condensation, ice ,rain, snow, hail; solar radiation below 700W/m ² , air pressure 70-106 kPa
	Temperature, humidity	-10~+50℃、20%~95%RH (No dewing)
	Vibration	Below 20Hz<0.5g
	Store temperature	-25~+60℃
	Installation	Hanging type, cabinet type
	Cooling mode	Forced air cooling

Product features

High product integration: three-in-one design (main motor, oil-cooled fan, motor fan), support single/dual frequency conversion scheme; integration of AC220V and DC24V power output, built-in anti-overcurrent fuse; single-frequency integration of oil-cooled fan control and overload protection functions, without additional contactors, thermal relays, transformers and other control devices;

AP100 series air compressor integrated machine supports wall mounting and vertical cabinet type installation, easy to install; product wiring debugging is simple and easy to operate;

Supports synchronous and asynchronous motors, supports open-loop and closed-loop control; and provides fast and stable pressure control. Eliminate extra waste and save energy; double-inverter fans use variable frequency control to further save energy;

3The double-inverter model of 30KW or above is equipped with a DC reactor as standard, which reduces external interference and improves the input side power factor;

The product software adopts special machine software, adopts HMI panel, special air compressor human-computer interaction interface, beautiful and easy to use; supports communication equipment such as Internet

of Things, can realize remote monitoring operation and other functions;

Integrated motor temperature sampling protection function can effectively prevent motor over temperature and motor demagnetization;

Integrated separate oil pump control;

Integrated cooling fan control of servo motor;

Integrated pressure sampling control.

2 Before use

2.1 Purchase Inspection

- On receiving your order, please check the package and confirm intact before opening, and check if there's any damage, scratch or dirt (damages caused during transportation are not within the company's warranty). If there's any damage caused during transportation, please contact us or the transport company immediately.

After confirming the receipt of the goods intact, please re-confirm if the product and your order are consistent. Model of the product is on the "MODEL" column. If you find the product model is not the one you ordered, please contact the dealer you purchased the product or the sales department of VEICHI immediately.

- Confirm that the equipment in the box matches the packing list.

2.2 Nameplate

2.2.1 Nameplate Position and Content

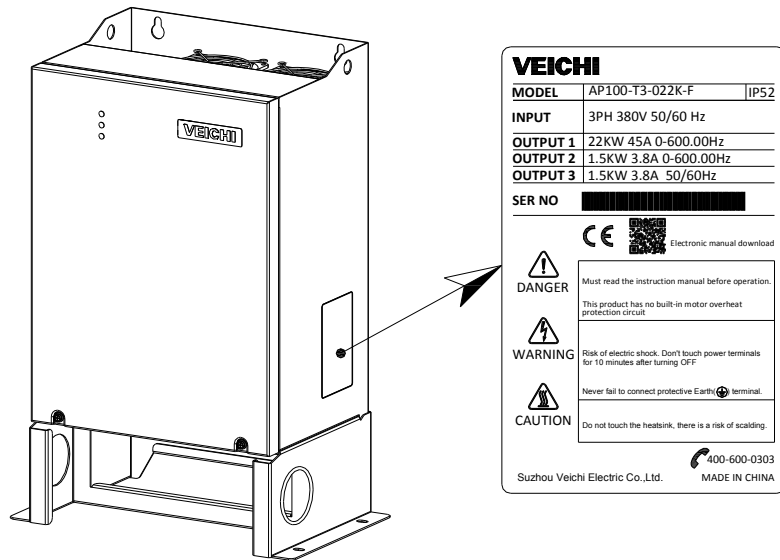

Drawing 2-1: Nameplate Position and Content

2.2.2 Model Specification

AP100 - T 3 - 037 K - F

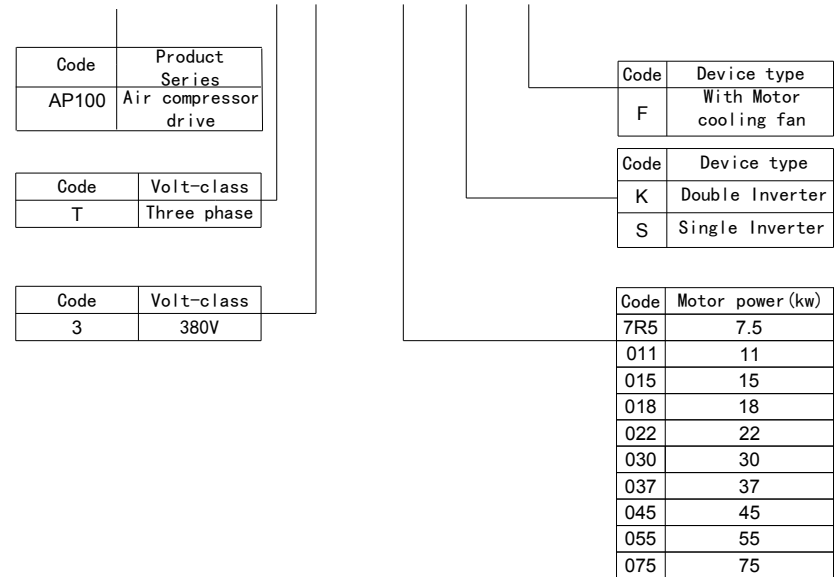

Drawing 2-4: Meaning and Naming Rules of AC200 Series Inverter Nameplate

2.2.3 AP100 parts description

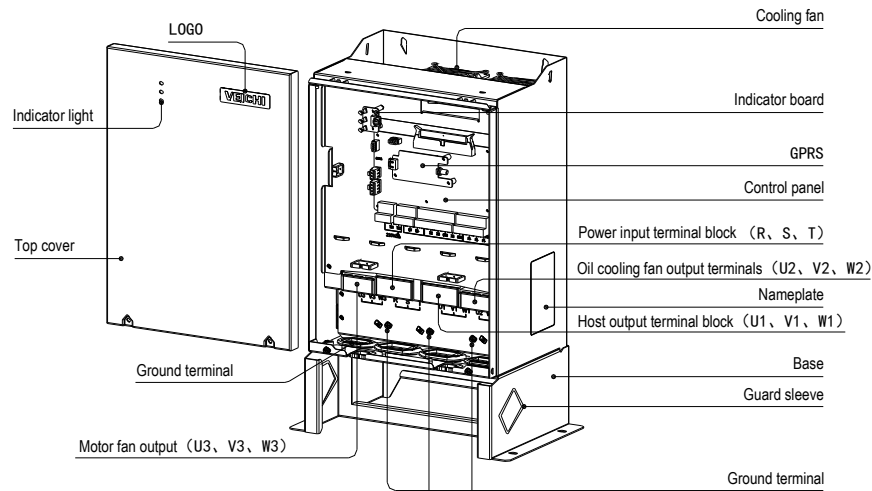

2.3 Air compressor integrated machine rated output current

main motor power (KW)	Rated output current (A)	Oil cooling fan power (KW)	Rated output current (A)	Fan power (KW)	Rated output current (A)
7.5	17	0.75	2.1	\	\
11	25	0.75	2.1	0.75	2.1
15	32	0.75	2.1	0.75	2.1
18	38	1.5	3.8	1.5	3.8
22	45	1.5	3.8	1.5	3.8
30	60	1.5	3.8	1.5	3.8
37	75	1.5	3.8	1.5	3.8
45	90	4	10	1.5	3.8
55	110	4	10	1.5	3.8
75	150	5.5	13	1.5	3.8

2.4 Product Size

2.4.1 Wall-Mounted Shape and Installation Dimensions

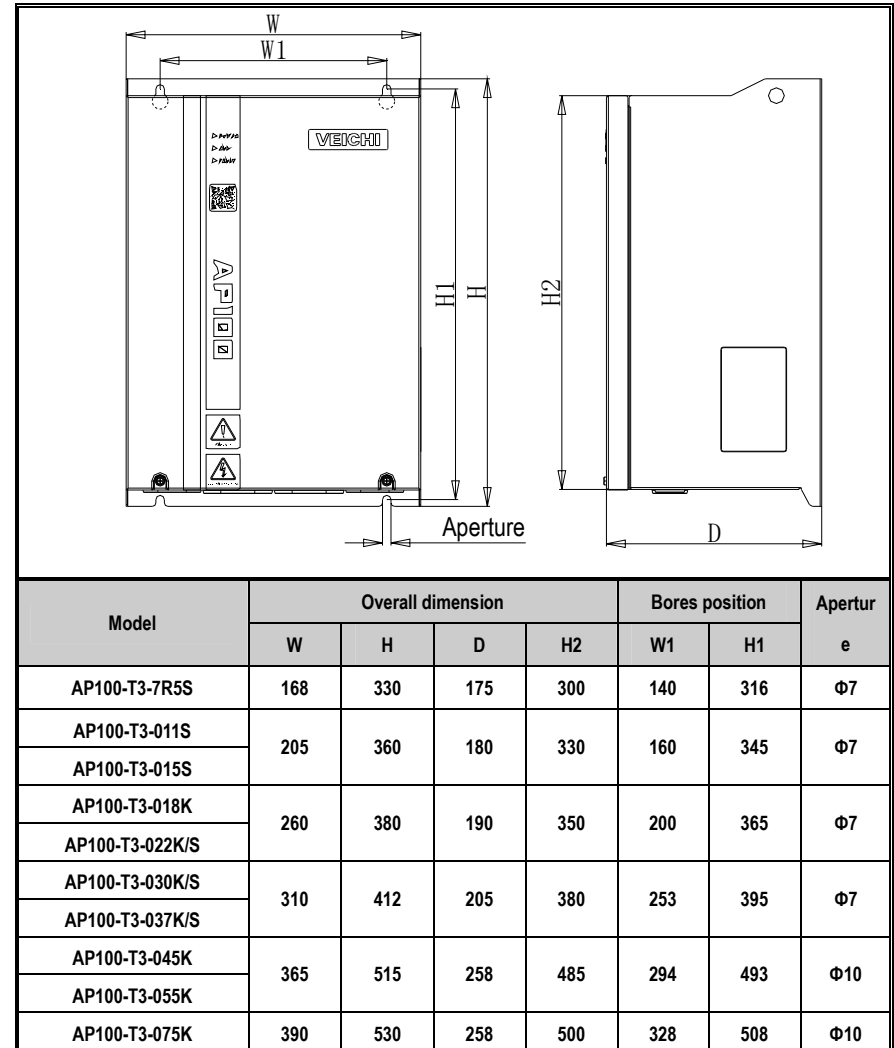

Figure 2-5: Diagram of wall-mounted shape and installation dimensions

2.4.2 Shape and Installation Dimension of Vertical Cabinet

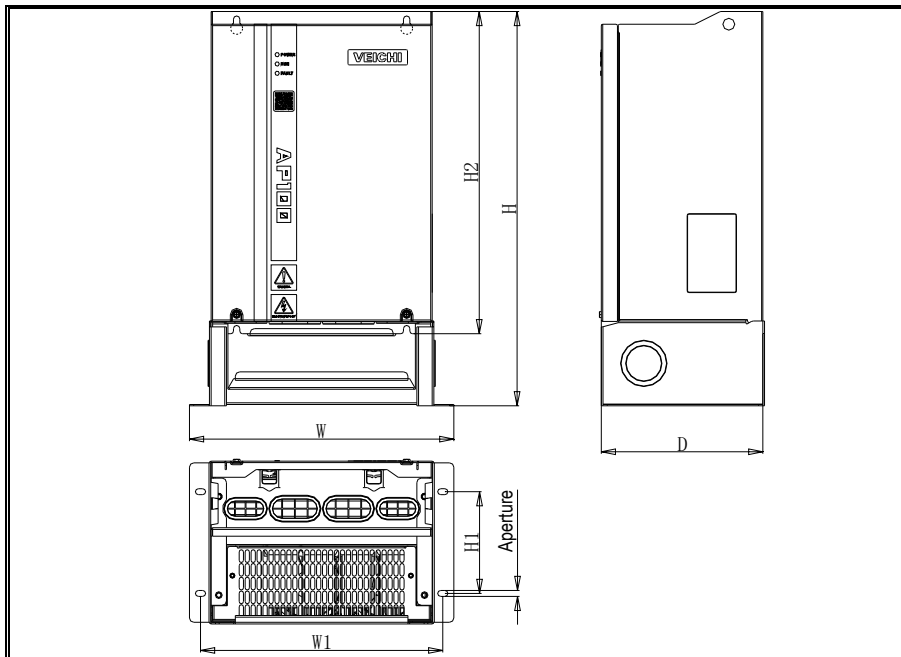

Figure 2-6: Drawing of the shape and installation dimensions of the vertical cabinet

Model	Overall dimension				Bores position		Aperture
	W	H	D	H2	W1	H1	
AP100-T3-7R5S	219	395	177	330	193	130	φ7
AP100-T3-011S	256	435	182	360	230	130	φ7
AP100-T3-015S							
AP100-T3-018K	311	465	192	380	285	140	φ7
AP100-T3-022K/S							
AP100-T3-030K/S	361	495	207	412	335	155	φ7
AP100-T3-037K/S							
AP100-T3-045K	426	616	260	515	400	200	φ10
AP100-T3-055K							
AP100-T3-075K	451	625	260	530	425	200	φ10

2.5 Mechanical Installation

2.5.1 Installation space requirements

In order to ensure the ventilation space and wiring space required for the cooling of the driver, it is important to observe the installation conditions shown in the figure below.

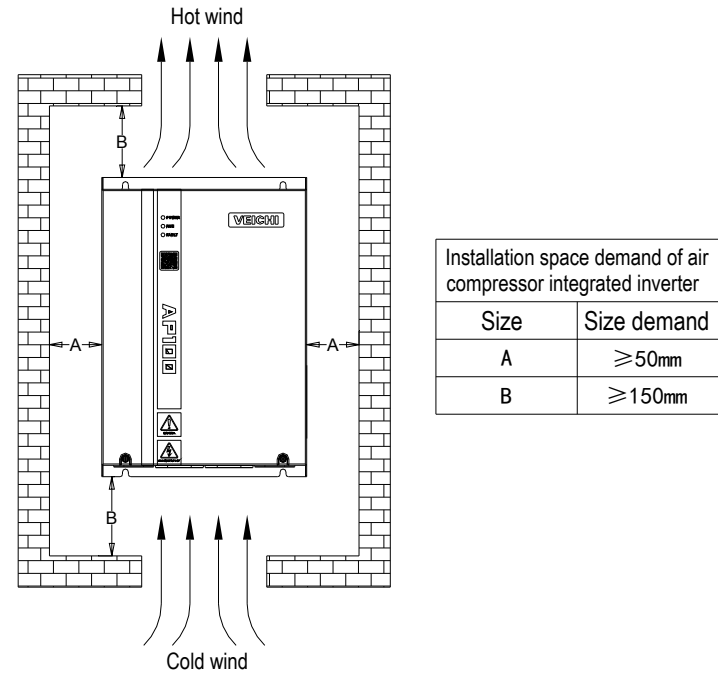

Figure 2-7: AP100 Series Installation Space Diagram

2.5.2 Disassembly and Installation of Cover Plate

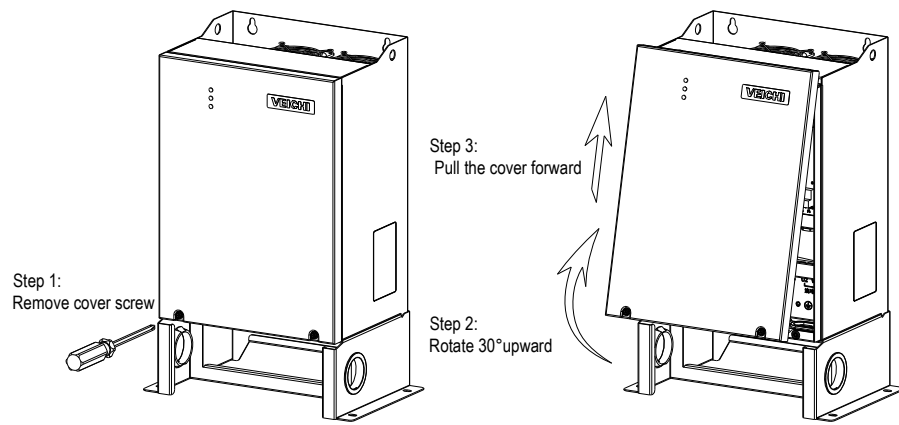
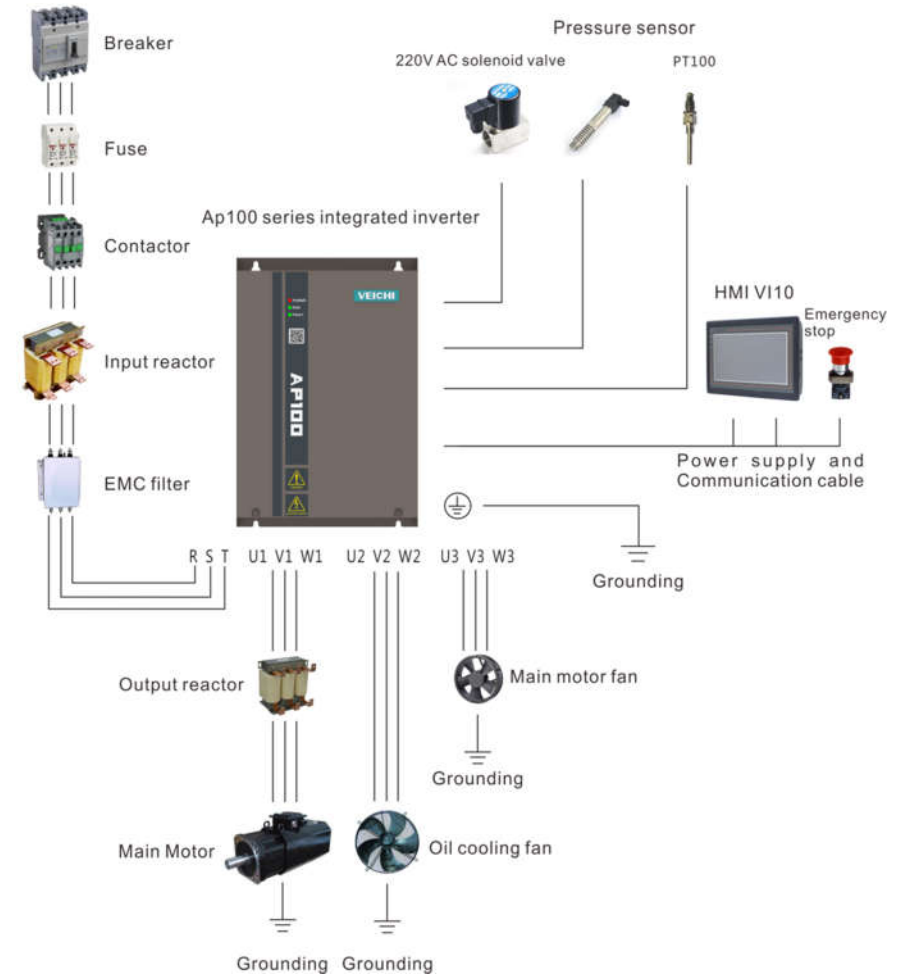



Figure 2-8: Diagram of removal and installation of cover plate

2.6 Electrical Installation

This section describes the various precautions and requirements that must be followed to ensure the safe use of the product by users, maximize the performance of the driver, and ensure the reliable operation of the drive

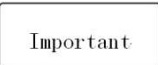

Safety Precautions

	<ul style="list-style-type: none"> • Must earth reliably while inverter is running. Otherwise there is danger of casualty and unstable inverter performance. • To ensure safe running, only trained professional person can do installation and wiring job. • No operation under power connected state. Otherwise there is danger of electric shock even death. • Before operation, please cut all related equipments power, ensure that the main circuit DC current has dropped to safe range. And please operate after 5 mins.
	<ul style="list-style-type: none"> • Control cable, power cable and motor cable must be separated. They can not be in the same cable trough or cable rack. • This equipment can only be used as the maker states. Please consult Veichi while using in special case.
	<ul style="list-style-type: none"> • No insulation test for the inverter or the related cable by HV insulation test equipment. • If the inverter or the peripheral equipment (filter, reactor and etc) needs insulation test, firstly 500V megohmmeter should be used to test the insulation resistance which should not be lower than 4MΩ.

2.6.1 Main circuit terminal

Definition and distribution of main circuit terminals (AP100-T3-7R5S, AP100-T3-022S, AP100-T3-037S model main circuit terminals are different)

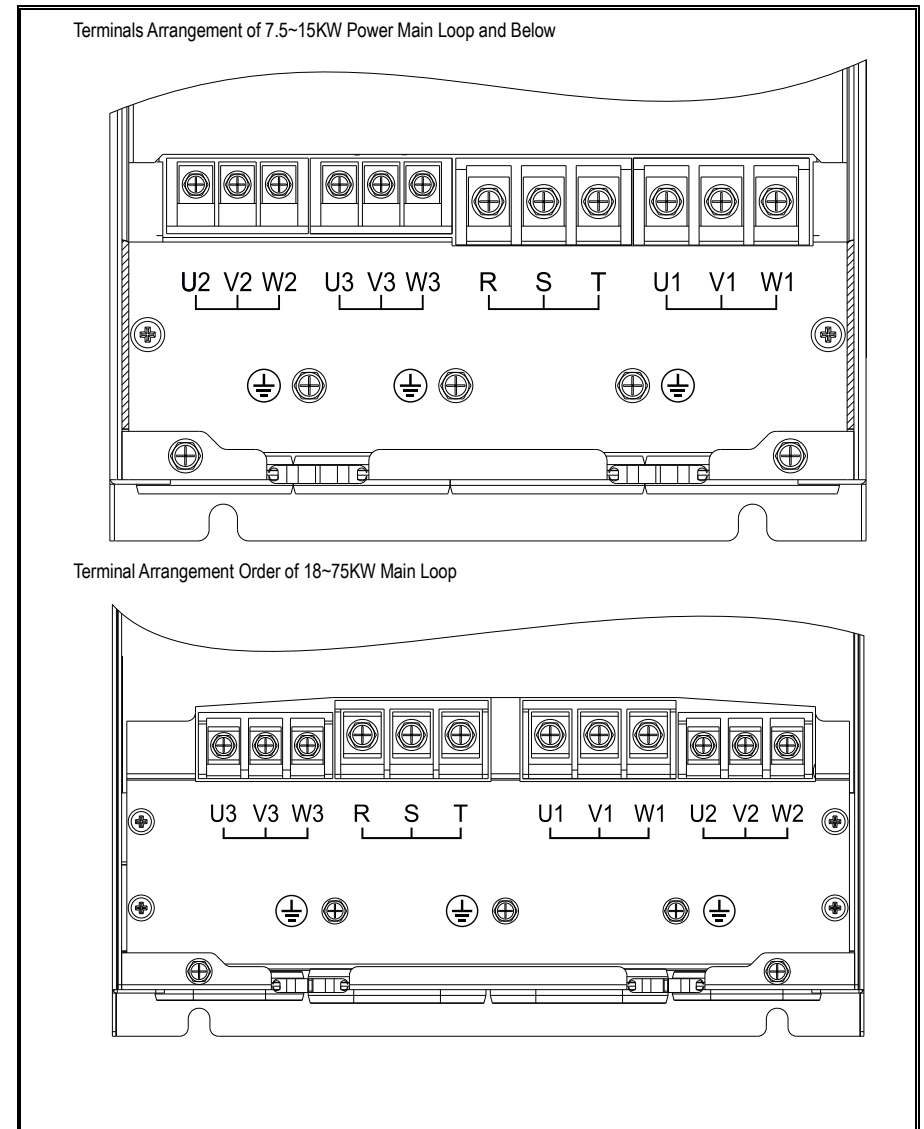

Terminal Sign	Terminal Name	Terminal Function Definition
U2 V2 W2	Output terminal of oil-cooling fan	Drive oil-cooling fan
U3 V3 W3	Connection terminal of motor cooling fan	Drive the motor cooling fan
R S T	Driver input terminal	Connect to the 380V power supply
U1 V1 W1	Host Output Terminal	Drive the main motor
⊕	Grounding terminal	Grounding terminal, grounding resistance < 10 ohms

2.6.2 Control Terminal Definition

Distribution Diagram of Terminal of 7.5~37KW Single Frequency Inverter S Type Control Board

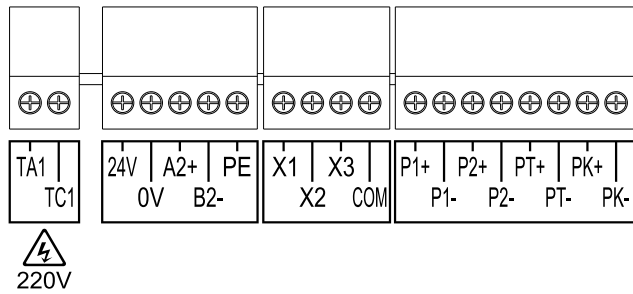

Distribution Diagram of Terminal of Control Board of 18~75KW Dual Frequency Inverter K Model

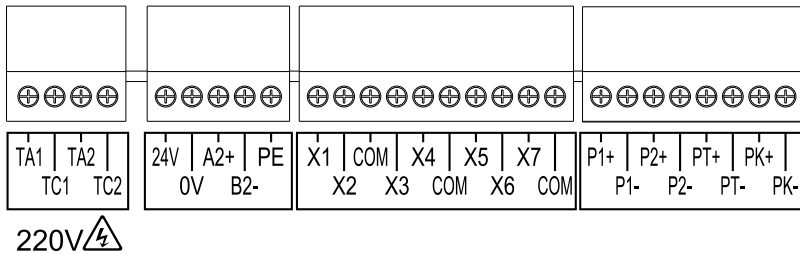

● Control Terminal Description

Classification	Terminal Sign	Terminal Function Specification	Technical Specification
Digital Input	X1~X7	Multifunctional input terminal, X1 for emergency stop, X4 for fan overload protection, X5 for host motor temp protection. (Single frequency conversion X1 is emergency stop, X3 is host motor temp protection)	Isolated bipolar digital signal input, level input voltage range: 10-30V, input impedance 4.4K
	COM	Multifunctional input terminal	
Power supply output	24V	External 24V Power Supply	+ 24V power supply output, accuracy (+5%), external output capacity 0.4A
	0V	24V Power Reference Ground	Internal independence from COM
	PE	The Ground Line of Touch Screen	Grounding terminal, grounding resistance < 10 ohms
RS485	A+	RS485 Communication+	Semi-duplex RS485 communication, baud rate < 250KBPS, this 485 signal contact touch screen communication port. Compatible with PT100 and KTY84 temperature sensors. Temperature range of - 20 ~250 C is measured. Temperature error is (+5 C).
	B-	RS485 Communication-	
Temperature Detection Input	PK+,PK-	Terminal of Motor Temperature Detection	- Temperature range of 20 ~250, temperature error (+5)
	PT+,PT-	PT100 Oil Temperature Detection Terminal	4-20mA input
Pressure Singal Input	P1+, P1-	Pressure sensor signal 1	Output of 24Vdc power supply, accuracy (+1%), external output 0.1A
	P2+, P2-	Pressure sensor signal 2	

Relay Output	TA1,TC1	Relay output, where TA1 TC1 defaults to solenoid valve	Internal independence from COM
	TA2,TC2		

2.6.3 Selection of Dial Switch on Control Board and Functional

Explanation of Its Corresponding Position

Switch number	Switch position	Functional description
S1	KTY PT2 	KTY: Motor temperature detection is KTY84 PT2: Motor temperature detection is PT100

2.6.4 Control terminal wiring diagram

Terminal wiring diagram of 7.5~37KW single frequency S type control board

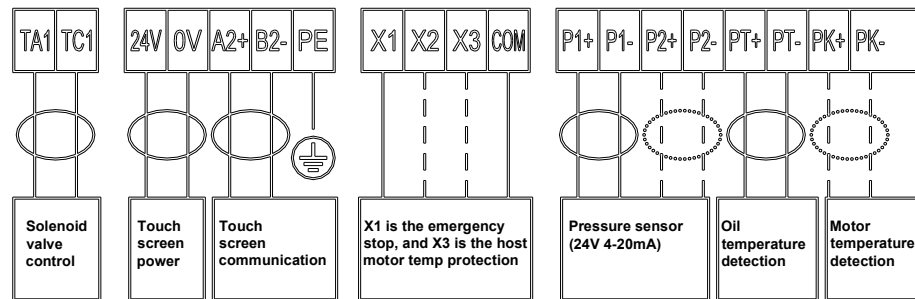

Hint: The solid line in the figure indicates the minimum recommended wiring when the system is running, and the dotted line indicates the optional wiring.

Terminal Connection Diagram of 18~75KW Dual Frequency Converter K Type Control Board

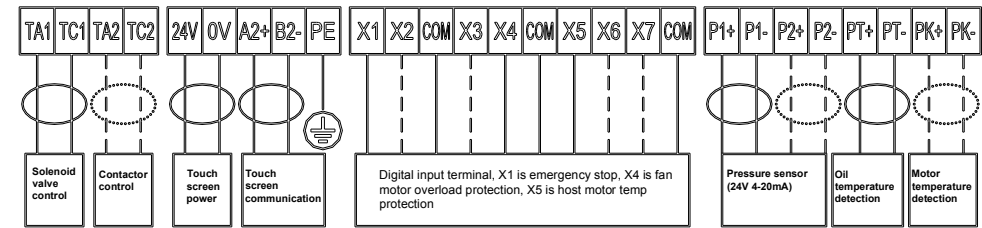

Hint: The solid line in the figure indicates the minimum recommended wiring when the system is running, and the dotted line indicates the optional wiring.

2.7 Indicator Description

AP100 series air compressor has three LED display lights, which display power supply, operation and fault respectively. The position of the display lamp is shown in the following figure

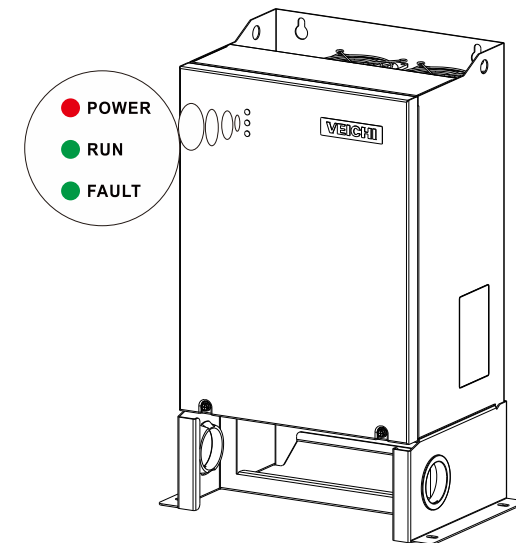

Figure 2-13: Indicator Position Diagram - Change Picture

3HMI Display and Operation

3.1 HMI Basic Operation and Display

The operation and display of AP100 are both completed on the HMI. The HMI enters the status display interface after power on.

3.1.1 Status Display

Indicator Status		Status Description
Power	● POWER	Lighting out: no power supply
Indicator	☀ POWER	Lighting: Power supply
Run	● RUN	Lighting out: shutdown
Indicator	☀ RUN	Lighting: Running
Fault	● FAULT	Lighting out: Normal state
Indicator	☀ FAULT	Lighting: Failure status

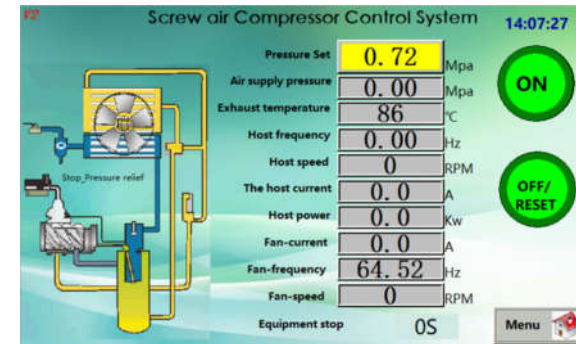

Fig. 3-1: Status Display Interface

The status display interface lists the basic information of air compressor and completes the operations: **Start & Stop** and **Pressure Setting**. Press and hold the **“ON”** button for more than 1 second at stop state to start the air compressor; press the **“Stop/Reset”** button while running to stop the air compressor; press the **“OFF/Reset”** button while faulty to releases the alarm after clearing all the faults.

Click **“Pressure Set”** to set the target pressure required by user. The air compressor is automatically loaded and unloaded according to the current pressure in the automatic loading mode. Click **“Menu”** to enter the corresponding parameters in the pop-up interface.

When the air compressor detects a fault, HMI will alarm and stop. And the air compressor can be only started normally after clearing the fault and resetting.

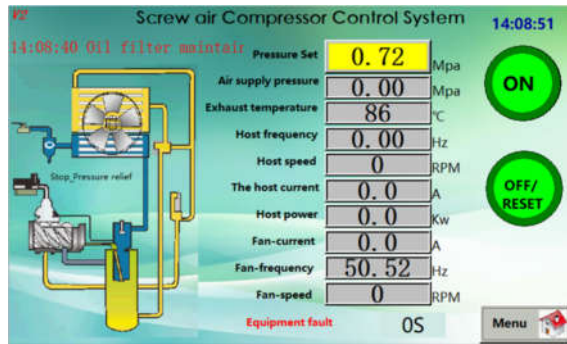

Fig. 3-2: Alarm Information

Note: Different power levels display slightly different in the oil cooling fan parameters.

3.1.2 Running Parameters

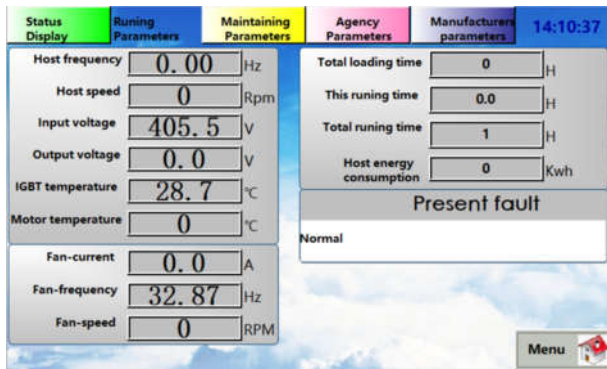

Fig. 3-3: Running Parameters Interface

The operating parameters show the detailed air compressor status. This fault displays the current air compressor fault information.

Note: Different power levels display slightly different in the fan parameters.

3.1.3 Maintaining parameters

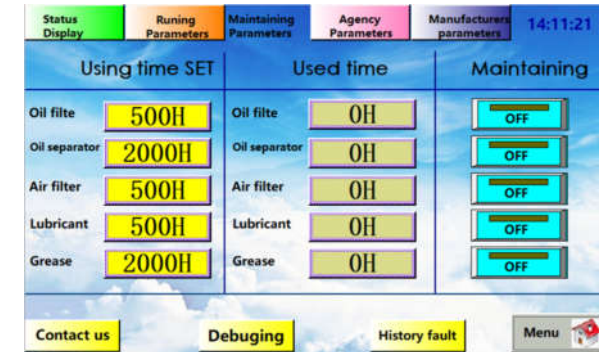

Fig. 3-4: Maintenance Parameters Interface

This interface shows the maintenance time and usage time of each component of the air compressor. When the "Used time" is more than "Using time", HMI will give a red prompt on the "Status Display" interface without stop when the "Maintaining" is off; and HMI will alarm and stop when the "Maintaining" is on. When the "Used time" is more than "Using time", user should replace the maintenance parts in time. Set the usage time to 0 to invalid the maintenance function and there is no alarm or stop when the "Used time" is more than "Using time".

The "Using time Setting", "Used time" and "Maintaining" can be modified after maintenance. Different types of operations require different level passwords. AP100 passwords adopts fixed passwords and random passwords. The passwords management is done by air compressor manufacturer and this manual does not explain for this.

There are three subpages on this page.

(1) **Contacts:**

The air compressor manufacturers or agents could edit their contact information on this page. The on-site staffs can contact relevant person when it reaches the maintenance time of each component.

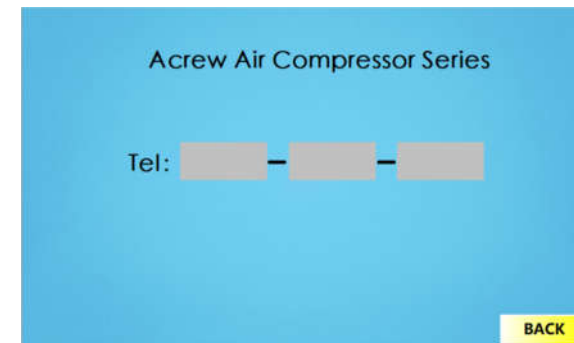

Fig. 3-5: Contacts

(2): History Fault

It is used to display the historical fault record and fault time of the air compressor, to help the technicians analyze the faults.

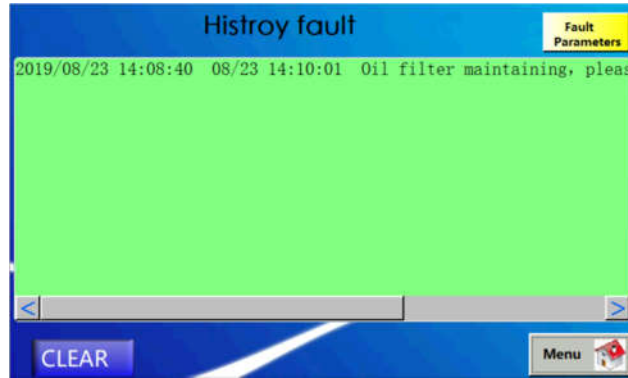

Fig. 3-6: History Fault

(3): Debugging Interface

It is used to display the status of analog and digital signals.

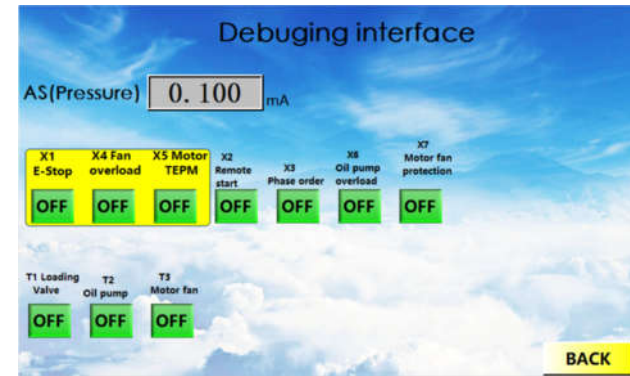

Fig. 3-7: Debugging Interface

3.1.4 Protection Parameters

No need password to enter the protection parameters. But the relevant password is needed when you need to modify the protection parameters, as shown in Fig. 3-6.



Fig. 3-8: Password Interface

The air compressor manufacturer will provide different operators with different passwords. The operators only need to enter the password provided by the manufacturer to perform corresponding operations. Please contact the air compressor manufacturer for dynamic password if the password level is not enough. All permissions will be cleared after returning to the status display interface. Please re-enter the password if you need to enter the "Protection Parameters" and "Manufacturer Parameters" again.

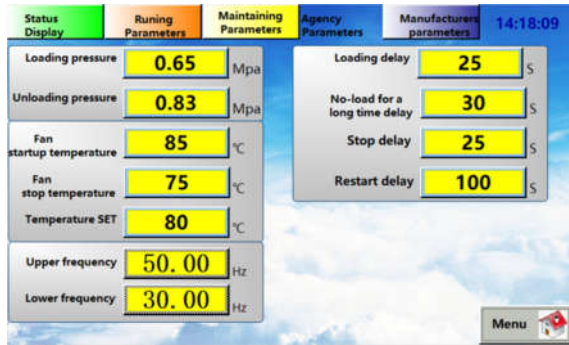

Fig. 3-9: Protection Parameters Interface

The protection parameter interface is mainly for the parameters set by air compressor manufacturer and agents, which can set the air compressor's loading/unloading pressure, fan start/stop temperature, loading valve and other things.

No-load for a long time delay: When the air compressor is in the unloading state, the controller starts timing. When the time exceeds the "No-load for a long time delay", the host stops and enters the sleep state. When the air supply pressure is lower than the loading pressure, the host restarts from the sleep state.

Stop delay: When the stop button is pressed or whole machine protection acts, the controller starts timing. When the time exceeds "Stop delay", the whole machine stops.

Restart delay: When air compressor is at stop, the controller starts timing. When the time exceeds the "Restart delay", the host is ready for the second startup.

3.1.5 Manufacturer Parameters

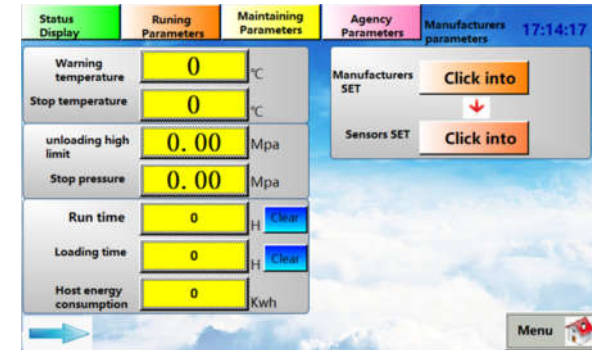

Fig. 3-10: Manufacturer Parameters Interface1

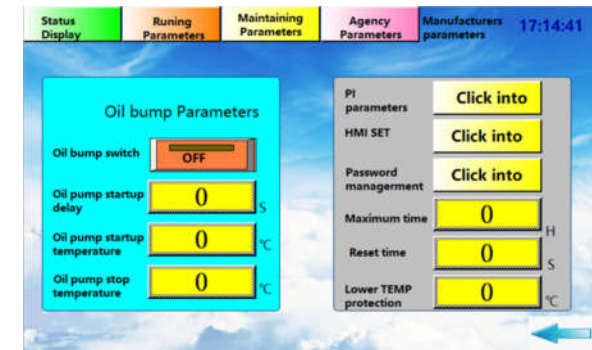

Fig. 3-11: Manufacturer Parameters Interface2

The manufacturer parameters are mainly the parameters set by air compressor manufacturer. Due to the different requirements of manufacturer, the parameters and password protection method are also different.

Warning temperature & Stop temperature: When the oil temperature is higher than the "Warning temperature", the status display interface will give a red prompt; when the oil temperature is higher than the "Stop temperature", HMI will alarm and stop.

Unloading high limit & Stop pressure: The unloading high limit is the maximum value of the unloading pressure, and the unloading pressure in protection parameter is limited by it. When the air pressure is higher than Stop pressure, air compressor will alarm and stop.

Oil pump switch: Sometimes a separate oil pump is needed for low-pressure air compressor. When the oil pump switch is turned on, the oil pump control is valid. When the oil temperature is higher than "Oil pump start up temperature", the oil pump is turned on; when the oil temperature is less than the "Oil pump stop temperature", the oil pump stops. The oil pump start delay is used to set the delay of the oil pump start signal.

PI parameters: Since the AP100 PID parameters can be adapted to various applications, this parameter does not need to be adjusted.

HMI SET: used to set parameters of the touch screen, such as: system clock, buzzer, etc.

Maximum time and Reset time: When the running time of air compressor is more than the maximum time, HMI will alarm and stop; the reset time is the time when the password needs to be re-authenticated. Password needs to be re-entered if it exceeds the reset time..

3.1.6 Manufacturer parameter setting

Show some internal information of the drive, as well as some important functions.

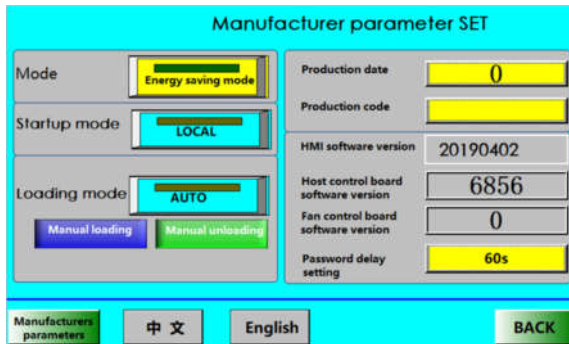

Fig. 3-12: Manufacturer parameter setting Interface

Startup mode: Please select "Local" when using HMI to operate the start/stop of air compressor; please select "Remote" when using X2 terminal external button to operate.

Loading mode: Select "Auto" and the air compressor will automatically load/unload according to the current pressure and time. Select "Manual" and the air compressor will not load under unloading condition. Only when "Air Supply pressure" is lower than "Loading pressure", click the "Manual loading" in the status display interface, the air compressor will be loaded. The manual loading mode can be used for intermittent and small amounts gas need, which can be stored in the gas tank and then manually refilled.

Mode selection: important parameters, please consult the drive manufacturer.

3.1.7 Sensor Parameters

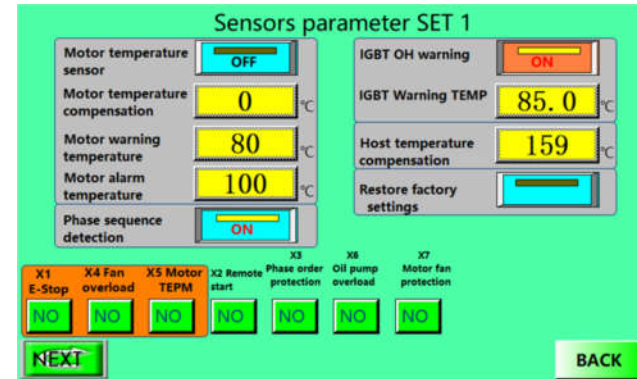

Fig. 3-13: Sensor Parameters 1

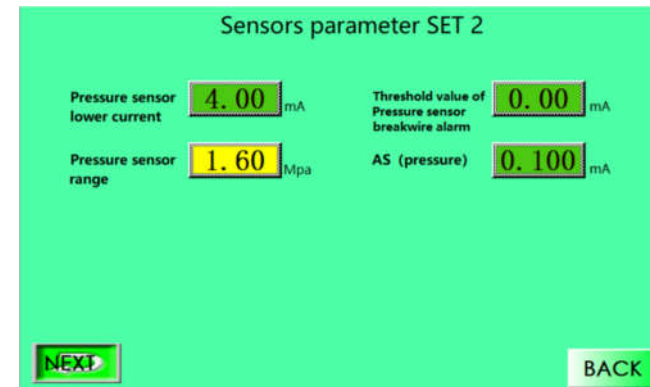

Fig. 3-14: Sensor Parameters 2

Click the sensor parameter option in the manufacturer parameter to enter the sensor parameter interface, which is mainly related to the air compressor digital input interface, temperature sensor and pressure sensor.

Digital input polarity: Some digital switches of the air compressor are normally open, some are normally closed.

Please set the polarity of digital input terminals as needed. **For some unused terminals, please set to normally open, otherwise it will cause malfunction or false alarm of air compressor.**

Motor temperature sensor: Click to select the motor temperature sensor (KTY84-130 or PT100) to measure the motor temperature in real time. When the motor temperature is higher than "Motor Pre-alarm Temperature", the status interface will give a prompt; when the motor temperature is higher than "Motor Alarm Temperature", HMI will alarm and stop.

Temperature compensation: There is a certain error between the motor temperature and oil temperature and the

correction is needed when the deviation is too large. The oil temperature is: the temperature measured by the oil temperature sensor + "Host Temperature Compensation"; the motor temperature is: the temperature measured by motor temperature sensor + "Motor Temperature Compensation".

Phase sequence protection: AP100 has its own phase sequence detection function. The default state is on.

Module overheat pre-alarm: When it is on, the status display interface gives a prompt but without stop when the drive module temperature exceeds the "Module Pre-alarm Temperature". This function is used in the harsh environment. When the drive air duct is blocked, the user is prompted to clean the air duct to avoid the driver's shutdown protection due to excessive temperature, which may cause unnecessary loss to users.

Factory default settings: Click the factory default settings to restore the HMI factory parameters of air compressor, including maintenance parameters, but the fault record will not be cleared. Before restoring the factory settings, the maintenance parameter values should be recorded and then manually entered. (This is to prevent missing air compressor parts maintenance time)

Pressure Sensor

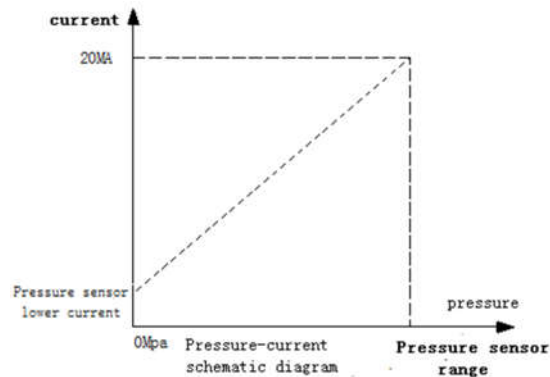

Fig. 3-15: Pressure-Current Diagram

Fig. 3-15 shows the relationship between the pressure sensor current and the corresponding pressure. The "Pressure sensor minimum current" is corresponding to the output current of pressure sensor at 0Mpa. The "Pressure sensor maximum range" is corresponding to the pressure of pressure sensor at 20ma, When the AS detection current is less than "Pressure disconnection threshold", the system determines the disconnection of pressure sensor and alarms to stop. AS value is the detected current at present; when there is error with pressure sensor sampling, the "Pressure sensor minimum current" and " Pressure sensor maximum range " can be adjusted to correct it.

3.1.8 Inverter Debugging

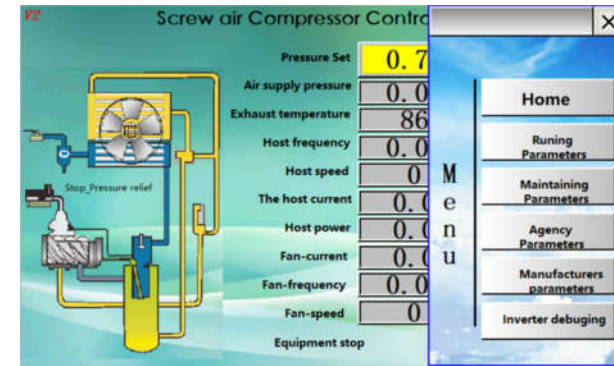

Fig. 3-16: Inverter Debugging

Click "Menu" in any interface and select the "Inverter Debugging" button to enter the inverter debugging interface. The drive parameter settings and trial running can be completed in this interface.

3.2 Motor Parameters

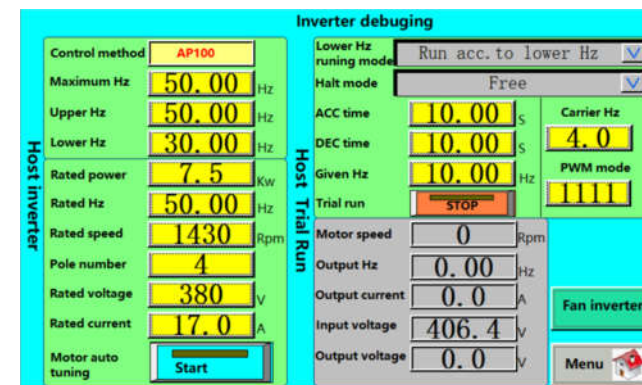

Fig. 3-17: Main motor – Motor Parameters Setting

Select the motor control mode and input motor parameters as per the nameplate into the corresponding input box. It does not need to input motor poles, which can be calculated automatically according to the speed and frequency. Clicking the "Start" button, drive will start to learn motor parameters, and the "Start" button will become "Learning". After 10S to complete the learning, "Learning" returns to "Start". If there is anything wrong during the learning process, click the "Learning" button to stop the motor self-learning immediately.

Notes: (1) The control mode is usually set by default and does not need to be set.

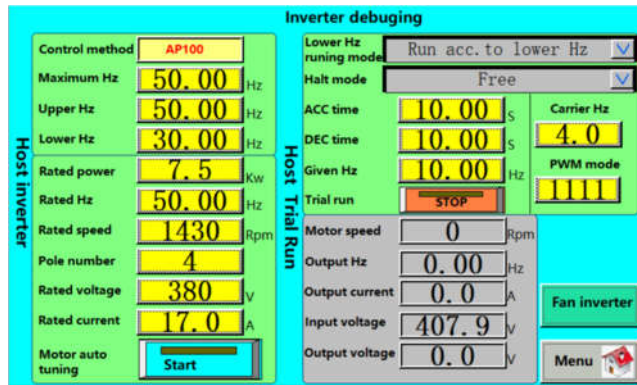

Fig. 3-18: Main Motor – Trial Running

After learning motor parameters, you can also complete the motor trial running in this interface. Set the “Given frequency” at first, and then click the host trial running button to check the motor running direction. If it is not correct, please click the trial running button again to stop the drive and exchange any two phases of the motor cables. Set the upper/lower limit frequency, the lower limit frequency operation mode, and the stop mode after the normal trial running of the drive.

3.2.1 Fan Parameters

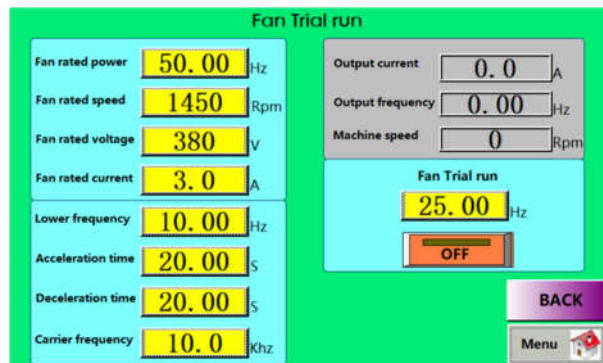

Fig. 3-20: Fan - Parameters Setting

The fan parameters are the drive parameter settings of dual-inverter oil-cooling fan. The single-inverter only displays the trial running button, and other parameters are not displayed. Enter the fan motor nameplate parameters into the fan parameters, set the frequency in the trial running box (usually 20 to 25Hz), and click the button below to check the fan direction. If it is not correct, please stop and change the fan phase sequence. Set the “Frequency Setting” to 50Hz to check the fan current.

3.2.2 Fault Parameters

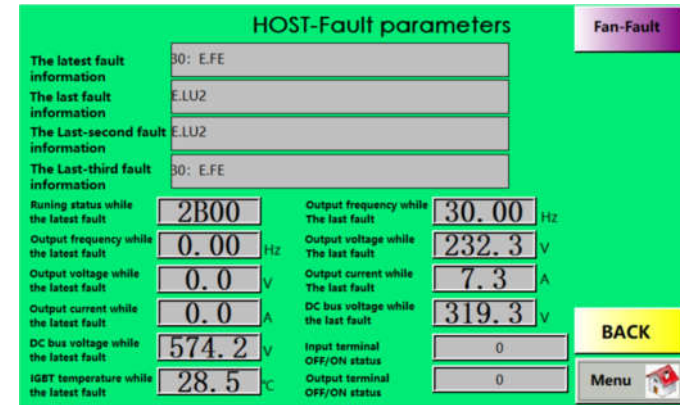

Fig. 3-22: Main Motor – Fault Parameters

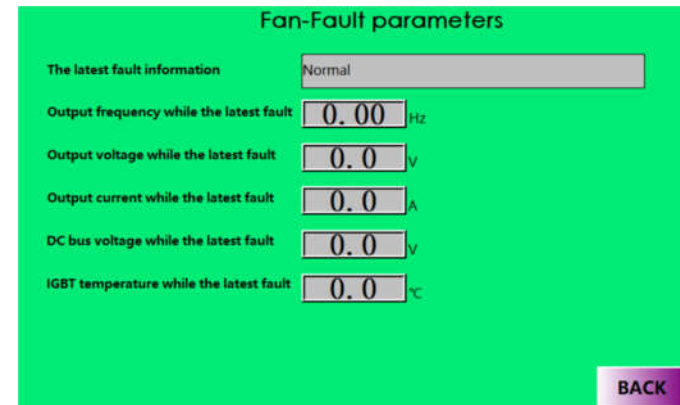

Fig. 3-23: Fan – Fault Parameters

The fault parameters record the current and previous fault status of the host drive and the oil-cooling fan drive for the manufacturer's reference.

4. Functional parameter table

4.1 External Keyboard

For debugging conveniently, AP100 driver's host frequency conversion control board and fan frequency conversion control board have keyboard interface. Users can use external keyboard to view and modify the host frequency conversion and fan frequency conversion parameters in more detail. The related parameters of the compressor are described below.

4.2 Main engine function parameter table of air compressor

- “●” : Indicates that this parameter can be changed when the driver is running;
- “○” : Indicates that this parameter is not changeable when the driver is running;
- “×” : Indicates that this parameter can only be read and cannot be changed;
- “ - ” : Indicates that this parameter is "factory parameter" and is limited to factory settings.;
- “※” : Indicates that this parameter is related to the model of driver;

Basic parameter group

Function Code Number	Function Code Name	Scope and Definition of Settings	Factory Setting	Attribute	address
F00.00	Motor Control Mode	Asynchronous motor control mode: 0:VF control 3: High Performance Vector Control without PG 4: High Performance Vector Control with PG Synchronous motor control mode: 6: High Performance Vector Control without PG 7: PG vector control 1, 2 and 5: Reservations	6	○	0x000
F00.01	Reservations				0x001
F00.02	Running Command Channel	0:Keyboard Control 1:Terminal Control 2:RS485 Communication Control 3:Reservation	2	●	0x002
F00.03	Frequency Source Given Channel A	0: Keyboard number given frequency 1: Reservation	0	●	0x003
F00.04	Frequency Source Given Channel B	2: Current/Voltage Analog AI1 Given 3: Current/Voltage Analog AI2 Given	1	●	0x004

		4: Reservations 5: Terminal Pulse PUL Given 6:RS485 Communication Given 7: Terminal UP/DW control 8:PID Control Given 9: Program Control (PLC) Given 10: Optional Card 11:Multistage Velocity Given			
F00.05	Frequency Channel B Reference Source	0:With the maximum output frequency as the reference source 1: Using A set frequency as reference source	0	●	0x005
F00.06	Frequency Source Given Selection	0:Channel A 1: Channel B 2: Channel A + Channel B 3: Channel A-Channel B 4: Maximum of channel A and B 5: Minimum of Channel A and B	0	●	0x006

F00.07	Run command bundling	Personal Bit: Keyboard Command Instruction Binding	0000	●	0x007
		Ten Bits: Terminal Command Instruction Binding			
		100 bits: communication command instruction Binding			
		Thousand Bits: Buy Card Command Binding			
		0: No bundles			
		1: Keyboard number given frequency			
		2: Reservations			
		3: Current/Voltage Analog AI1 Given			
		4: Current/Voltage Analog AI2 Given			
		5: Reservations			
6: Terminal Pulse PUL Given					
7:RS485 Communication Given					
8: Terminal UP/DW Control					
9:PID Control Given					
A: Program Control (PLC) Given					
B: Optional Card					
C: Multi-segment speed setting					
F00.08	Keyboard Number Setting Frequency	0.00~upper limit frequency	50.00Hz	●	0x008
F00.09	Maximum frequency	Upper Limit Frequency to 600.00Hz	50.00Hz	○	0x009
F00.10	Upper Limit Frequency Source Selection	0: Digital setting of upper limit frequency	0	●	0x00A
		1: Reservation			
		2: Current/Voltage Analog AI1 Given			
		3: Current/Voltage Analog AI2 Given			
		4: Reservations			
		5: Terminal Pulse PUL Given			
		6:RS485 Communication Given			
7: Optional Card					
F00.11	Digital Setting of Upper Limit Frequency	Lower Limit Frequency to Maximum Frequency	50.00Hz	●	0x00B
F00.12	Lower Limit Frequency	0.00~upper limit frequency	0.00Hz	●	0x00C
F00.13	Lower Limit Frequency Operation Mode	0: Stop the output and enter the suspension state	1	○	0x00D

		1: Operate at the lower limit frequency			
F00.14	Acceleration time 1	0.01~650.00s	According to model	※	0x00E
F00.15	Deceleration time 1	0.01~650.00s	According to model	※	0x00F
F00.16	Selection of Rotation Direction	LED Bit: Operating Direction Reverse	0000	○	0x010
		0: Direction unchanged 1: Direction reversed			
		LED Ten Bits: Operating Direction Prohibited			
		0: Allow positive and negative commands 1: Only positive commands are allowed			
2: Only reverse commands are allowed					
LED 100 Bits: Frequency Control Command Direction					
		0: Frequency control direction is invalid 1: Frequency control direction is effective			
		LED 1000 bits: reserved			
F00.17	G/P Model Setting	0: G Model 1: P Model	0	●	0x011
F00.18	Reservation				0x012
F00.19	Parameter initialization	0: no operation	0	○	0x013
		1: Restore factory value (without restoring motor parameters)			
		2: Restore factory value (restore motor parameters)			
		3: Clear the fault record			

Operational Control Parameter Group

Function Code Number	Function Code Name	Scope and Definition of Settings	Factory Setting	Attribute	address
F01.00	Start-up operation mode	0: Started by startup frequency	0	○	0x100
		1: First DC brake and then start from start frequency			
		2: Re-start after speed tracking and direction judgment			
F01.01	Start-up pre-excitation time	0.00~60.00s	0.00s	○	0x101
F01.02	Start-up frequency	0.00~60.00Hz	0.50Hz	○	0x102

F01.03	Start duration frequency	0.0~50.0s	0.0s	○	0x103
F01.04	Pre-start braking current	0.0~150.0%	60.0%	○	0x104
F01.05	Pre-start braking time	0.0~60.0s	0.0s	○	0x105
F01.06	Speed tracking	0.00~60.00s	0.50s	○	0x106
F01.07	Speed tracking shutdown delay	0.00~60.00s	1.00s	○	0x107
F01.08	Reservation				
F01.09	Reservation				
F01.10	Stop Mode	0 : Deceleration shutdown 1: Free Shutdown	0	●	0x10A
F01.11	Starting Frequency of DC Brake in Stop	0.00~50.00Hz	1.00Hz	○	0x10B
F01.12	DC braking current during shutdown	0.0~150.0%	60.0%		0x10C
F01.13	Reservation				0x10D
F01.14	DC Brake Duration of Shutdown	0.0~60.0s	0.0s	○	0x10E
F01.15	Outage detection frequency	0.00~50.00Hz	0.50Hz	●	0x10F
F01.16	Acceleration and deceleration	LED bits: time benchmark selection 0: Maximum Frequency 1: Fixed Frequency 50Hz 2: Set Frequency LED Ten Bits: S Acceleration and Deceleration Selection 0:linear acceleration and deceleration 1:S curve acceleration and deceleration LED 100 bits, 1000 bits: reserved	0010	○	0x110
F01.17	Accelerated Start S Curve Time	0.00~10.00	0.20s	○	0x111
F01.18	Accelerated End S Curve Time	0.00~10.00	0.20s	○	0x112
F01.19	Starting S-curve time of deceleration	0.00~10.00	0.20s	○	0x113
F01.20	S-curve time at deceleration end	0.00~10.00	0.20s	○	0x114
F01.21	Acceleration time 2	0.01~650.00s	10.00s	●	0x115
F01.22	Deceleration time 2	0.01~650.00s	10.00s	●	0x116

F01.23	Acceleration time 3	0.01~650.00s	10.00s	●	0x117
F01.24	Deceleration time 3	0.01~650.00s	10.00s	●	0x118
F01.25	Acceleration time 4	0.01~650.00s	10.00s	●	0x119
F01.26	Deceleration time 4	0.01~650.00s	10.00s	●	0x11A
F01.27	Emergency parking deceleration time	0.01~650.00s	1.00s	●	0x11B
F01.28	Positive and Reverse Dead Zone Time	0.0~120.0s	0.0s	○	0x11C
F01.29	Zero-speed Torque Frequency Threshold	0.00~10.00Hz	0.50Hz	●	0x11D
F01.30	Zero-speed Torque Holding Coefficient	0.0~150.0%	60.0%	●	0x11E
F01.31	Zero-speed Torque Holding Time	0.0~6000.0s When set to 6000.0s, keep it	0	●	0x11F
F01.32-F01.34	Reservation				
F01.35	Power outage restart action	0: Invalid 1: Valid	0	○	0x123
F01.36	Waiting time for power outage restart	0.00~60.00s	0.50s	○	0x124
F01.37	Reservation				0x125
F01.38	Frequency setting of point operation	0.00-max frequency	5.00Hz	●	0x126
F01.39	Point acceleration time	0.01~650.00s	10.00s	●	0x127
F01.40	Point deceleration time	0.01~650.00s	10.00s	●	0x128
F01.41	Jump frequency 1	0.00-max frequency	0.00Hz	●	0x129
F01.42	Jump frequency amplitude 1	0.00-max frequency	0.00Hz	●	0x12A
F01.43	Jump frequency 2	0.00-max frequency	0.00Hz	●	0x12B
F01.44	Jump frequency amplitude 2	0.00-max frequency	0.00Hz	●	0x12C

Switching terminal parameter group

Function Code Number	Function code name	Scope and Definition of Settings	Factory Setting	Attribute	address
F02.00	Input terminal 1 (X1)	Refer to the 4.2 Function Selection Table	6	○	0x200
F02.01	Input terminal 2 (X2)	Refer to the 4.2 Function Selection Table	1	○	0x201
F02.02	Input terminal 3 (X3)	Refer to the 4.2 Function Selection Table	80/82	○	0x202
F02.03	Input terminal 4 (X4)	Refer to the 4.2 Function Selection Table	81	○	0x203
F02.04	Input terminal 5 (X5)	Refer to the 4.2 Function Selection Table	82	○	0x204

F02.05	Input terminal 6 (X6 extension)	Refer to the 4.2 Function Selection Table	86	○	0x205	
F02.06	Input terminal 7 (X7 extension)	Refer to the 4.2 Function Selection Table	87	○	0x206	
F02.07	Input terminal 8 (X8 extension)	Refer to the 4.2 Function Selection Table	0	○	0x207	
F02.08	Input terminal 9 (X9 extension)	Refer to the 4.2 Function Selection Table	0	○	0x208	
F02.09	Input terminal 10 (X10 extension)	Refer to the 4.2 Function Selection Table	0	○	0x209	
F02.10	Selection of X1-X4 Terminals	0: Closure is effective 1: Disconnection is effective Personal: X1	Ten: X2 Hundred: X3 1000 bits: X4	0001	●	0x20A
F02.11	Selection of X5-X8 Terminals	0: Closure is effective 1: Disconnection is effective Personal: X5	Ten: X6 Hundred: X7 1000 bits: X8	0000	●	0x20B
F02.12	Selection of X9-X10 Terminals	0: Closure is effective 1: Disconnection is effective Personal: X9	Ten: X10 Hundreds: Reservations Thousands: Reservations	0000	●	0x20C
F02.13	Effective detection delay of X1	0.000~6.000s	0.010	●	0x20D	
F02.14	Invalid Detection Delay of X1	0.000~6.000s	0.010	●	0x20E	
F02.15	Effective detection delay of X2	0.000~6.000s	0.010	●	0x20F	
F02.16	Invalid Detection Delay of X2	0.000~6.000s	0.010	●	0x210	
F02.17	Effective detection delay of X3	0.000~6.000s	0.010	●	0x211	
F02.18	Invalid Detection Delay of X3	0.000~6.000s	0.010	●	0x212	

F02.19	Effective detection delay of X4	0.000~6.000s	0.010	●	0x213
F02.20	Invalid Detection Delay of X4	0.000~6.000s	0.010	●	0x214
F02.21	Effective detection delay of X5	0.000~6.000s	0.010	●	0x215
F02.22	Invalid Detection Delay of X5	0.000~6.000s	0.010	●	0x216
F02.23	Terminal Control Operation Mode	0: Two-wire system 1 1: Two-wire system 2 2: Three-wire system 1 3: Three-wire system 2	0	○	0x217
F02.24	Terminal Start Protection	0: Close 1: Open LED Bit: Start Protection when Exit Abnormal LED Ten Bits: Point Protection when Exit Abnormal LED 100 bits: Start protection when command channel is switched to terminal	0111	○	0x218
F02.56-F02.59 Reservation					
F02.42	Output terminal polarity selection	0: Positive polarity 1: Negative polarity LED Bit: Relay Output T1 LED Ten Bits: Relay Output T2 LED 100 bits: Relay output T3 LED 1000 bit: Extended Relay Output 2	0000	●	0x22A

F02.43	Relay Output T1/Loading Valve	Refer to the 4.2 Function Selection Table	40	●	0x22B
F02.44	Relay Output T2/Oil Secondary Fan	Refer to the 4.2 Function Selection Table	43/41	●	0x22C
F02.45	Relay Output T3/Motor Fan	Refer to the 4.2 Function Selection Table	42	●	0x22D
F02.46				●	0x22E
F02.47	Relay Output T1	0.000~6.000s	0.010	●	0x22F
F02.48	Relay Output T2	0.000~6.000s	0.010	●	0x230
F02.49	Relay Output T3	0.000~6.000s	0.010	●	0x231

F02.50				●	0x232
F02.51	Output Frequency Level 1 (FDT1)	0.00-max frequency	30.00	●	0x233
F02.52	FDT1 hysteresis	0.00-max frequency	1.00H	●	0x234
F02.53	Output Frequency Level 2 (FDT2)	0.00-max frequency	50.00	●	0x235
F02.54	FDT2 hysteresis	0.00-max frequency	1.00H	●	0x236
F02.55	Given frequency to reach detection value	0.00~50.00Hz	2.00Hz	●	0x237

Analog terminal parameter set

Function Code Number	Function Code Name	Scope and Definition of Settings	Factory Setting	Attribute	address	
F03.00	P1 Lower Limit Value	0.00~10.00V	0.00V	●	0x300	
F03.01	P1 Lower Limit Correspondence Setting	-100.00~100.00%	0.00%	●	0x301	
F03.02	P1 upper limit	0.00~10.00V	10.00V	●	0x302	
F03.03	P1 Upper Limit Correspondence Setting	-100.00~100.00%	100.00%	●	0x303	
F03.04	P1 filtering time	0.000~6.000s	0.100s	●	0x304	
F03.05	Reservation					
F03.06	P2 Lower Limit Value	0.00~10.00V	0.00V	●	0x306	
F03.07	P2 Lower Limit Correspondence Setting	-100.00~100.00%	0.00%	●	0x307	
F03.08	P2 upper limit	0.00~10.00V	10.00V	●	0x308	
F03.09	P2 Upper Limit Correspondence Setting	-100.00~100.00%	100.00%	●	0x309	
F03.10	P2 filtering time	0.000~6.000s	0.100s	●	0x30A	
F03.11	Reservation					
F03.12	Functional Selection of AI1 Terminals	Refer to X terminal function	0	○	0x30C	
F03.13	AI1 High Level Setting	0.00~100.00%	70.00%	●	0x30D	
F03.14	AI1 Low Level Setting	0.00~100.00%	30.00%	●	0x30E	
F03.15	Functional Selection of AI2 Terminals	See X terminal function	0	○	0x30F	
F03.16	AI2 High Level Setting	0.00~100.00%	70.00%	●	0x310	
F03.17	AI2 Low Level Setting	0.00~100.00%	30.00%	●	0x311	
F03.18	Analog Quantity Setting Terminal Effective State	0:Low level 1: High level LED bit: AI1	LED Ten Bits: AI2 LED hundred bits: reserved	0000	●	0x312

			LED thousand bits: reserved		
F03.19	Selection of Analog Input Curve	LED bit: AI1 0: Line (default) 1: Curve 1: Curve 12: Curve 2 LED Ten Bits: AI2 LED 100 bits: reserved LED 1000 bits: reserved	0000	●	0x313
F03.20	Reservation				0x314
F03.21	Lower Limit Value of Curve 1	0.00~10.00V	0.00V	●	0x315
F03.22	Corresponding Setting of Lower Limit of Curve 1	0.00~100.00%	0.0%	●	0x316
F03.23	Curve 1 inflection point 1 input voltage	0.00~10.00V	3.00V	●	0x317
F03.24	Corresponding Setting of Curve 1 Inflection Point 1	0.00~100.00%	30.00%	●	0x318
F03.25	Curve 1 inflection point 2 input voltage	0.00~10.00V	6.00V	●	0x319
F03.26	Corresponding Setting of Curve 1 Inflection Point 2	0.00~100.00%	60.00%	●	0x31A
F03.27	Curve 1 upper limit	0.00~10.00V	10.0V	●	0x31B
F03.28	Correspondence Setting of Curve 1 Upper Limit	0.00~100.00%	100.00%	●	0x31C
F03.29	Lower Limit Value of Curve 2	0.00~10.00V	0.00V	●	0x31D
F03.30	Corresponding Setting of Lower Limit of Curve 2	0.00~100.00%	0.00%	●	0x31E
F03.31	Curve 2 inflection point 1 input voltage	0.00~10.00V	3.00V	●	0x31F
F03.32	Corresponding Setting of Curve 2 Inflection Point 1	0.00~100.00%	30.00%	●	0x320
F03.33	Curve 2 inflection point 2 input voltage	0.00~10.00V	6.00V	●	0x321
F03.34	Curve 2 inflection point 2 corresponding setting	0.00~100.00%	60.00%	●	0x322
F03.35	Curve 2 upper limit	0.00~10.00V	10.00V	●	0x323

F03.36	Correspondence Setting of Curve 2 Upper Limit	0.00~100.00%	100.00%	●	0x324
--------	---	--------------	---------	---	-------

System parameter group

Function Code Number	Function Code Name	Scope and Definition of Settings	Factory Setting	Attribute	address
F04.00	Selection of parameters and key lock	0: Not locked 1: Functional parameter locking 2: Functional parameters and key lock (except RUN/STOP/JOG) 3: Full lock of function parameters and keys	0	●	0x400
F04.01	Parametric group password	0~65535	0	●	0x401
F04.02-F04.04	Reservation				
F04.05	Copy of parameters	0: No function 1: Transducer parameter value is transferred to keyboard and saved 2: Keyboard saved parameters are transferred to frequency converter	0	○	0x405
F04.06	Selection of Keyboard Special Functions	LED bits: built-in and external keyboard key commands 0: External priority, when the external is valid, the built-in is invalid 1: Built-in priority. When built-in is valid, the built-in is invalid. 2: Both internal and external devices are valid, and stop/reset commands are preferred. LED Ten Bits: Reserved LED 100 bits: reserved	0000	○	0x406
F04.07	Keyboard REV/JOG Selection	0:REV (inversion) 1:JOG (click)	0	○	0x407

F04.08	Keyboard STOP Key Settings	0: Invalid non-keyboard control 1: Non-keyboard control mode shutdown mode 2: Non-keyboard control mode shutdown in free mode	1	○	0x408
F04.09	Keyboard Up and Down Key Selection	LED Bit: Keyboard Up and Down Key (Digital Potentiometer) Modification Selection 0: Invalid 1: Keyboard for frequency adjustment given F00.08 2: Used to adjust P LED Ten Bits: Power-off Storage 0: Frequency power off without storage 1: Frequency power-off storage LED 100 bits: movement limitation 0: Operational shutdown adjustable 1: Only adjustable in operation and maintained during downtime.	0011	○	0x409
F04.10	Keyboard Up and Down Keys Modify Parameter Number Settings	Ten bits of LED: YY setting in Fxx.yy LED 100-bit 1000-bit: XX settings in Fxx.yy For example, "0008" means F00.08	0008	○	0x40A
F04.11-F04.13	Reservation				
F04.14	The first line of keyboard shows parameter 1 circularly	Ten bits of LED: YY setting in Cxx.yy LED 100-bit 1000-bit: XX settings in Cxx.yy For example, "0000" means C00.00	0000	●	0x40E
F04.15	The first line of keyboard shows parameter 2 in a loop	Same as above	0001	●	0x40F
F04.16	The first line of the keyboard shows the parameter 3 in a loop.	Same as above	0002	●	0x410

F04.17	The first line of keyboard shows parameter 4 in a loop	Same as above	0011	●	0x411
F04.18	Keyboard second line circular display parameter 1	Same as above	0002	●	0x412
F04.19	Keyboard second line circular display parameter 2	Same as above	0004	●	0x413
F04.20	Keyboard second line circular display parameter 3	Same as above	0010	●	0x414
F04.21	Keyboard second line circular display parameter 4	Same as above	0012	●	0x415
F04.22	Keyboard Display Item Settings	LED Bit: Output Frequency Display 0:Target Frequency 1:Operating Frequency LED 100 Bits: Power Display Dimension 0:Percentage 1:KW	0000	●	0x416
F04.23	Monitoring Display Selection	LED bits: self-learning display monitoring parameters 0: invalid 1: valid LED Bit: C05 Group Display Selection Relevant parameters of 0-1:VF mode 2:VC Mode Related Parameters LED 100 bits: C00.40~C00.69 display selection 0:No Display 1:Display	0000	●	0x417
F04.24	Speed Display Coefficient	0.0~500.0%	100.0%	●	0x418
F04.25	Power Display Coefficient	0.0~500.0%	100.0%	●	0x419
F04.26	Alarm Selection 1	LED bits: E.EEP failure (EEPROM storage failure) 0:Alarm and shut down freely 1: Alarm and continue operation	0000	○	0x41A
F04.27	Reservation				0x41B

F04.28	FAN Control	0: The Fan runs after that inverter is powered on 1: shutdown is dependent with temperature, running means working 2: not running means not working, running is dependent with temperature	1	●	0x41C
F04.29	Energy brake enable	0: off 1: Turn on the energy brake and turn off the overvoltage suppression 2: Simultaneously enable energy braking and overvoltage suppression	2	●	0x41D
F04.30	Energy consumption braking action voltage	T3: 650-800V (default 740V) T2/S2: 350-390V (default 360V)	Model set	●	0x41E
F04.31	Reservation				0x41F
F04.32	PWM Carrier	0.7~16.0kHz	Model set	※	0x420
F04.33	PWM Control model	LED bits: carrier is related with temperature 0: not related with temperature 1: related with temperature LED 10 bits: carrier is related with output frequency 0: not related 1: related LED100 bits: random PWM enable 0: prohibited 1: enable LED 1000 bits: PWM modulation 0: only use 3 phase modulation 1: 2 phase and 3 phase modulation switch automatically	1111	●	0x421

Motor parameter group

Function No.	Function code name	Set value range and definition		Factory setting	Attributes	address
F05.00	Motor type	0: Asynchronous motor (AM)	1: Permanent magnet synchronous motor (PM)	0	×	0x500
F05.01	Number of motor poles	2~98		Model set	○	0x501
F05.02	Motor rated power	0.1~1000.0kW		Model set	※	0x502
F05.03	Motor rated frequency	0.01~最大频率		Model set	※	0x503
F05.04	Motor rated speed	1~65000rpm		Model set	※	0x504
F05.05	Motor rated voltage	1~1500V		Model set	※	0x505

F05.06	Motor rated current	0.1~3000.0A		Model set	※	0x506
F05.07	AM no-load current	0.1~3000.0A		Model set	※	0x507
F05.08	AM Stator resistance	0.01~50.00%		Model set	※	0x508
F05.09	AM rotor resistance	0.01~50.00%		Model set	※	0x509
F05.10	AM stator leakage inductance	0.01~50.00%		Model set	※	0x50A
F05.11	AM stator inductance	0.1~2000.0%		Model set	※	0x50B
F05.12	Synchronous stator resistance	0.01~50.00%		Model set	※	0x50C
F05.13	Synchronous machine d-axis inductance	0.01~200.00%		Model set	※	0x50D
F05.14	Synchronous machine q-axis inductance	0.01~200.00%		Model set	※	0x50E
F05.15	Synchronous back electromotive force	1~1500V		Model set	※	0x50F
F05.16	Synchronous encoder mounting angle	0.0°~360.0°		Model set	※	0x510
F05.17-F05.19 Reservation						
F05.20	Motor parameter auto-tuning selection	0: no operation 1: Rotary self-learning	2: Static self-learning 3: Stator resistance learning	0	○	0x514
F05.21	Synchronous motor magnetic pole search function	LED bits: closed loop vector 0: turn off 1: turn on 2: turn on at first power-on LED 10bits: open loop vector 0: turn off 1: turn on 2: turn on at first power-on		0010	○	0x515
F05.22-F05.29 Reservation						
F05.30	Speed feedback or encoder type	LED bits: encoder 0: ABZ encoder 1: resolver LED10 bits: encoder direction 0: Consistent direction; 1: Opposite direction LED100 bits: Wire break detection 0: turn off 1: turn on LED 1000 bits: Z Pulse correction 0: turn off 1: turn on		0000	○	0x51E
F05.31	ABZ encoder line number	1~10000		1024	○	0x51F
F05.32	Wire break detection	0.100~60.000s		2.000s	●	0x520

	time				
F05.33	No. of resolver poles	2~128	2	○	0x521
F05.34	Encoder transmission ratio molecule	1~32767	1	○	0x522
F05.35	Encoder Transmission ratio denominator	1~32767	1	○	0x523
F05.36	Encoder speed first-order filtering	0.0~100.0ms	1.0ms	●	0x524
F05.39	PG feedback monitoring selection	bits: C00.29 monitors PG feedback speed 0: no effective, 1: effective	0	●	0x527
F05.40-F05.49 Reservation					

Motor vector control group

Function No.	Function code name	Set value range and definition	Factory setting	Attributes	address
F06.00	ASR (speed loop) proportional gain 1	0.01~100.00	10.00	●	0x600
F06.01	ASR(speed loop) Integration time 1	0.000~6.000s	0.200s	●	0x601
F06.02	ASR Filtering time 1	0.0~100.0ms	0.0ms	●	0x602
F06.03	ASR Switching frequency 1	[F6.07]~Maximum frequency	0.00Hz	●	0x603
F06.04	ASR(speed loop) proportional gain 2	0.01~100.00	10.00	●	0x604
F06.05	ASR(speed loop) Integral time 2	0.000~6.000s	0.200s	●	0x605
F06.06	ASR Filtering time 2	0.0~100.0ms	0.0ms	●	0x606
F06.07	ASR Switching frequency 2	0.00~[F6.03]	5.00Hz	●	0x607
F06.08	Electric torque limit	0.0~250.0%	180.0%	●	0x608
F06.09	Power generation torque limit	0.0~250.0%	180.0%	●	0x609
F06.10	Current loop D-axis proportional gain	0.001~4.000	1.000	●	0x60A
F06.11	Current loop D-axis integral gain	0.001~4.000	1.000	●	0x60B
F06.12	Current loop Q-axis proportional gain	0.001~4.000	1.000	●	0x60C
F06.13	Current loop Q-axis integral gain	0.001~4.000	1.000	●	0x60D
F06.15	Vector control slip compensation	0.0~250.0%	100.0%	●	0x60F
F06.16 Reservation					
F06.18	Position compensation control	0: turn off 1: turn on	0	○	0x612
F06.19	Compensation gain	0.0~250.0%	0.0%	○	0x613
F06.20	Compensation limit	0.0~100.0%	0.0%	○	0x614
F06.21	Compensation range	0.0~100.0%	10.0%	○	0x615

F06.22	Overexcitation braking gain	0.0~500.0%	100.0%	○	0x616
F06.23	Overexcitation braking limit	0.0~250.0%	100.0%	○	0x617
F06.24	Vctor control energy savig function	0: turn off 1: only valid at constant speed 2: valid at constand speed, acceleration and deceleration	0	○	0x618
F06.25	Energy saving control gain	0.0~80.0%	50.0%	●	0x619
F06.26	Energy saving low-pass filtering	0.000~6.000s	0.010s	●	0x61A
F06.27	Motor constant power aone power limit	0.0~250.0%	200.0%	●	0x61B
F06.28	Motor weak current upper limit	0.0~250.0%	60.0%	○	0x61C
F06.29	Motor weak magnetic Feedforward gain	0.0~200.0%	10.0%	●	0x61D
F06.30	Motor weak magnetic	0.0~500.0%	10.0%	●	0x61E
F06.32	MTPA gain	0.0~400.0%	100.0%	●	0x620
F06.33	MTPA filtering time	0.0~100.0ms	1.0ms	●	0x621
F06.34	Reservation				0x622
F06.35	Low frequency pull-in current	0.0~50.0%	10.0%	●	0x623
F06.36	High frequency pull-in current	0.0~50.0%	10.0%	●	0x624
F06.37	Pull-in current frequency	0.0~100.0%	10.0%	●	0x625
F06.38-F06.69	Reservation				

Motor V/F control parameter

Function No.	Function code name	Set value range and definition	Factory setting	Attributes	address
F08.00	Linear VF curve selection	0: straight line VFcurve ; 1-9: separately power of 1.1-1.9 VFcurve; 10: square VFcurve; 11: customize VFcurve;	0	○	0x800
F08.01	Self-setting voltage V1	0.0~100.0%	3.0%	○	0x801
F08.02	Self-setting frequency F01	0.00~Maximum frequency	1.00Hz	○	0x802
F08.03	Self-setting voltage V2	0.0~100.0%	28.0%	○	0x803
F08.04	Self-setting frequency F02	0.00~Maximum frequency	10.00Hz	○	0x804
F08.05	Self-setting voltage V3	0.0~100.0%	55.0%	○	0x805
F08.06	Self-setting frequency F03	0.00~Maximum frequency	25.00Hz	○	0x806
F08.07	Self-setting voltage V4	0.0~100.0%	78.0%	○	0x807

F08.08	Self-setting frequency F04	0.00~Maximum frequency	37.50Hz	○	0x808
F08.09	Self-setting voltage V5	0.0~100.0%	100.0%	○	0x809
F08.10	Self-setting frequency F05	0.00~Maximum frequency	50.00Hz	○	0x80A
F08.11	Output voltage percentage	25.0~120.0%	100.0%	○	0x80B
F08.12	Torque boost	0.0~30.0%	0.0%	●	0x80C
F08.13	Torque boost cutoff frequency	0.0~100.0%	100.0%	●	0x80D
F08.14	Slip compensation gain	0.0~200.0%	100.0%	●	0x80E
F08.15	Slip compensation limit	0.0~300.0%	100.0%	●	0x80F
F08.16	Slip compensation filter time	0.000~6.000s	0.200s	●	0x810
F08.17	Oscillation suppression gain	0.0~900.0%	100.0%	●	0x811
F08.19	Automatic energy saving control	0: turn off 1: turn on	0	○	0x813
F08.20	Energy saving step down lower frequency limit	0.0~50.00Hz	15.00Hz	○	0x814
F08.21	Energy saving step down lower voltage limit	20.0~100.0%	50.0%	○	0x815
F08.22	Energy saving step down Voltage regulation rate	0.000~0.200V/MS	0.010V/MS	●	0x816
F08.23	Energy saving step down Voltage recovery rate	0.000~2.000V/MS	0.200V/MS	●	0x817
F08.24-F08.34	Reservation				

Protection and fault parameter set

Function No.	Function code name	Set value range and definition	Factory setting	Attributes	address
F10.00	Overcurrent suppression	0: suppression continues to work 1: valid at acceleration; invalid at constant speed	0	●	0xA00
F10.01	Overcurrent suppression point	0.0 ~ 300.0%	160.0%	●	0xA01
F10.02	Overcurrent suppression gain	0.0 ~ 500.0%	100.0%	●	0xA02
F10.03	Current hardware protection settings	LED bits: current limit by filterings 0: turn off 1: turn on LED 100 bits: OC interference suppression 0: turn off 1: primary interference suppression 2: Secondary interference suppression LED 100 bits: SC interference	1001	○	0xA03

		suppression 0: turn off 1: primary interference suppression 2: Secondary interference suppression LED 1000 bits: SC、OC reset delay function 0: not effective 1: effective			
F10.04	Reservation				0xA04
F10.05	Reservation				0xA05
F10.06	Bus overvoltage suppression	LED bit: overvoltage suppression 0: prohibited 1: Only enabled during deceleration 2: Enable under acceleration and deceleration LED 10 bits: overexcitation control 0: turn off 1: turn on LED 100 and 1000 bits: Reservation	0012	○	0xA06
F10.07	Bus overvoltage suppression point	T3: 650-780V(default 750) T2/S2: 340-380V (default 365)	Model set	※	0xA07
F10.08	Bus overvoltage suppression gain	0.0 ~ 500.0%	100.0%	●	0xA08
F10.09	Bus undervoltages suppression function	0: prohibited 1: enable	0	○	0xA09
F10.10	Bus undervoltage suppression point	T3: 350-450V (default 430) T2/S2: 180-260V (default 240)	Model set	※	0xA0A
F10.11	Bus undervoltage suppression gain	0.0 ~ 500.0%	100.0%	●	0xA0B
F10.12	Bus undervoltage protection point	T3: 300-400V (default 320) T2/S2: 160-240V (default 190)	Model set	※	0xA0C
F10.13	Input phase loss threshold	0.0 ~ 30.0%	10.0%	○	0xA0D
F10.14	Power-on short circuit detection	LED bit: power-on short circuit detection to ground 0: turn off 1: power-on detection 2: detect when runs every time LED 10 bits: power-on fan short circuit detection 0: turn off 1: turn on	11	○	0xA0E
F10.15	Phase loss protection	LED bit: output phase loss 0: turn off 1: turn on LED Ten bits: input phase loss 0: turn off 1: turn on fault warning 2: turn on fault alarm LED Hundred and Thousand bits : Reserved	0021	○	0xA0F

F10.16	Motor overload protection ratio	0.0~250.0%	100.0%	○	0xA10
F10.17	Load warning checkout setting	LED bit: checkout selection (protection 1) 0: not detecting 1: excessive detecting load 2: excessive detecting load only at constant speed 3: insufficient detecting load 4: Insufficient load detection only at constant speed LED10 bits: alarm selection 0: turn on fault warning, keep running 1: turn on fault alarm protection, and free parking LED 100bits:checkout selection (protection2) 0: not detecting 1: excessive detecting load 2: excessive detecting load only at constant speed 3: insufficient detecting load 4: Insufficient load detection only at constant speed	0000	○	0xA11
F10.18	Load warning detection level 1	0.0~200.0%	130.0%	○	0xA12
F10.19	Load warning detection time 1	0.0~60.0s	5.0s	○	0xA13
F10.20	Load warning detection level 2	0.0~200.0%	30.0%	○	0xA14
F10.21	Load warning detection time 2	0.0~60.0s	5.0s	○	0xA15
F10.22	Reservation				0xA16
F10.23	Excessive speed deviation protection action	LED bits: detecting selection 0: not detecting 1: detecting only at constant speed 2: always detecting LED 10bits: alarm selection 0: free stop and fault alarm 1: turn on fault warning and continue to run LED 100 and 1000bits: reservation	0000	○	0xA17
F10.24	Excessive speed deviation detection threshold	0.0~60.0%	10.0%	○	0xA18
F10.25	Excessive speed deviation detection time	0.0~60.0s	2.0s	○	0xA19

F10.26	High speed protection action	LED bits: detecting selection 0: not detecting 1: detecting only at constant speed 2: always detecting L LED 10bits: alarm selection 0: free stop and fault alarm 1: turn on fault warning and continue	0002	○	0xA1A
F10.27	High speed detection threshold	0.0~150.0%	110.0%	○	0xA1B
F10.28	High speed detection time	0.000~2.000s	0.050s	○	0xA1C
F10.29	Motor overheat protection selection (extended)	LEDbits: Temperature detection type selection 0: PT1000 1: KTY84 (PT100 preferred by the dial switch) LED10bits: temperature detection action 0: not detecting 1: warn and free parking	0001	○	0xA1D
F10.30	Motor overheat protection threshold (extended)	0.0~200.0 °C (fault alarm exceeded the threshold E.oH3)	110.0	○	0xA1D
F10.31	Motor overheat warning threshold (extended)	0.0~200.0 °C (fault alarm exceeded the threshold A.oH3)	90.0	○	0xA1E
F10.32-F10.37 reservation					

Communication control function parameter group

Function No.	Function code name	Set value range and definition	Factory setting	Attributes	address
F13.00	Master-slave selection	LED bits: Modbus communication master-slave selection 0: slave 1: master LED 10 to 1000bits: reservation	0000	○	0xD00
F13.01	485 communication address	1~247	1	○	0xD01
F13.02	Communication baud rate selection	LED bits: 485 communication 0: 1200 bps 1: 2400 bps 2: 4800 bps 3: 9600 bps 4: 19200 bps 5: 38400 bps LED 10 to 1000bits: reservation	0004	○	0xD02
F13.03	Modbus data format	0: (N, 8, 1) format 3: (N, 8, 2) format 1: (E, 8, 1) format 4: (E, 8, 2) format 2: (O, 8, 1) format 5: (O, 8, 2) format	0	○	0xD03
F13.04	Communication ratio setting	0.00~5.00	1.00	●	0xD04

F13.05	Communication respond delay	0~500ms		0ms	●	0xD05
F13.06	Communication timeout fault time	0.1~100.0s		1.0s	●	0xD06
F13.07	Communication fault action mode selection	0: do not detect timeouts 1: warn and free parking	2: warn and keep running 3: forced shutdown	0	●	0xD07
F13.08	Modbus response processing	0: have response	1:no response	0	●	0xD08
F13.09	Master send selection	LEDbit: first group send selection 0: not effective 1: run command 2: give precise frequency 3: output frequency 4: upper limit frequency 5: give precise torque 6: master output torque 7-8: reservation 9: master give precise PID A: master feedback PID LED 10bits: second group send selection LED 100bits: third group send selection LED 1000bits: fourth group send selection same as above		0031	●	0xD09
F13.10	RS485 communication port configuration	0: configured as Modbus communication	1: configured as series communication	0	●	0xD0A

Air compressor dedicated parameter setting

Function No.	Function code name	Set value range and definition	Factory setting	Attributes	address
F14.00	Air compressor control mode selection	LED bits: Air compressor control mode 0: general model 1: air compressor LED 10 to 1000bits: reservation	0001	○	0xE00
F14.01	Loading pressure	0.00Mpa~Setting pressure	0.65Mpa	●	0xE01
F14.02	Setting pressure	Loading pressure~Unload pressure	0.72Mpa	●	0xE02
F14.03	Unload pressure	Setting pressure~Upper limit pressure	0.78Mpa	●	0xE03
F14.04	Upper limit pressure	Unload pressure~Shutdown	0.85Mpa	●	0xE04
F14.05	Shutdown alarm	Shutdown alarm pressure~	0.90Mpa	●	0xE05
F14.06	Oil cooling fan stop temperature	0°C~setting temperature	75 °C	●	0xE06
F14.07	Setting temperature	Oil cooling fan stop temperature~Oil cooling fan start temperature	80 °C	●	0xE07

F14.08	Oil cooling fan start temperature	setting temperature ~150℃	85℃	●	0xE08
F14.09	Warning temperature	0℃ ~ shutdown alarm temperature	95℃	●	0xE09
F14.10	Shutdown alarm temperature	Warning temperature ~200℃	105℃	●	0xE0A
F14.11	Used Oil filter time	0 ~ 65535h	0	●	0xE0B
F14.12	Oil filter maintenance time	0 ~ 65535h :0 Invalid representative	500	●	0xE0C
F14.13	Used oil separator time	0 ~ 65535h	0	●	0xE0D
F14.14	oil separator maintenance time	0 ~ 65535h :0 Invalid representative	2500	●	0xE0E
F14.15	Used air filter time	0 ~ 65535h	0	●	0xE0F
F14.16	Air filter maintenance time	0 ~ 65535h :0 Invalid representative	500	●	0xE10
F14.17	Used lubricant oil time	0 ~ 65535h	0	●	0xE11
F14.18	lubricant oil maintenance time	0 ~ 65535h :0 Invalid representative	0	●	0xE12
F14.19	Used lubricant grease time	0 ~ 65535h3	0	●	0xE13
F14.20	lubricant grease maintenance time	0 ~ 65535h :0 Invalid representative	0	●	0xE14
F14.21	maintenance action setting 1	LED bits: oil filter 0: warning remind 1: Alarm and shutdown LED 10bits: oil separator 0: warning remind 1: Alarm and shutdown LED 100 bits: Air filter 0: warning remind 1: Alarm	0	●	0xE15
F14.22	maintenance action setting 2	LED bits: lubricant grease 0: warning remind 1: Alarm and shutdown LED 10 to 1000bits: reservation	0	●	0xE16
F14.23	Fault self-recovery times	0 ~ 10 times	3 times	●	0xE17
F14.24	Fault self-recovery time	0 ~ 1000S	10S	●	0xE18
F14.25	System function setting	LED ones: 0: Off fault self-reset; 1: Reset except OC, SC fault; 2: Reset except SC fault; 3: Reset all faults LED ten: overspeed function 0: off 1: open LED hundred to thousands: reserved	0002	●	0xE19

F14.26	Load delay	0 ~ 5000S	10S	●	0xE1A
F14.27	Empty car delay	0 ~ 5000S	300S	●	0xE1B
F14.28	Stop delay	0 ~ 5000S	15S	●	0xE1C
F14.29	Restart delay	0 ~ 5000S	30S	●	0xE1D
F14.30	Reserved			●	0xE1E
F14.31	operation time	0 ~ 65535h	0h	●	0xE1F
F14.32	Cumulative power consumption	0 ~ 65535Kwh	0Kwh	●	0xE20
F14.33	Maximum running time setting	0 ~ 65535h: 0 means invalid	0h	●	0xE21
F14.34	Load time	0 ~ 65535h	0h	●	0xE22
F14.35	Start load mode setting	LED ones: loading mode 0: Auto 1: Manual LED ten: manual loading and unloading 0: No action 1: Action LED Hundreds: Reserved LED Thousands: Control Mode 0: short range 1: remote	0000	●	0xE23
F14.36	Sensor selection channel	LED unit position: pressure sensor channel 0: P1 1: P2 LED ten: PK channel selection 0: PT100 1: KTY84-130 LED Hundreds: Oil Temperature Sensor Channel 0: PT 1: PK LED Thousands: Motor Temperature Sensor Channel 0: None 0: PK 1: PT	0010	●	0xE24
F14.37	Pressure sensor lower limit	0.00 ~ 20.00ma	4.00ma	●	0xE25
F14.38	Pressure sensor maximum range	0.00 ~ 10.00Mpa	1.60Mpa	●	0xE26
F14.39	Pressure disconnection alarm threshold	0.00 ~ 10.00ma	1.00ma	●	0xE27
F14.40	Host temperature compensation	-50 ~ 50℃	0℃	●	0xE28
F14.41	Motor warning temperature	20℃ ~ Motor alarm temperature	80℃	●	0xE29
F14.42	Motor alarm temperature	Motor warning temperature ~ 200℃	100℃	●	0xE2A
F14.43	Motor temperature compensation	-50 ~ 50℃	0℃	●	0xE2B

F14.44	Motor fan start delay	0~5000S	3S	●	0xE2C
F14.45	Motor fan stop delay	0~5000S	10S	●	0xE2D
F14.46	Oil pump start delay	0~5000S	5S	●	0xE2E
F14.47	Oil pump shutdown temperature	0℃ ~ Oil pump opening temperature	77℃	●	0xE2F
F14.48	Oil pump opening temperature	Oil pump shutdown temperature~200℃	87℃	●	0xE30
F14.49	Reserved			●	0xE31
F14.50	Reserved			●	0xE32
F14.51	Module warning temperature	0~200.0℃	70.0℃	●	0xE33
F14.52	Low temperature protection temperature	-30~100℃	-20℃	●	0xE34
F14.53	Sensor channel selection	LED unit: reserved LED ten: phase sequence protection 0: off 1: forward 2: reverse LED Hundreds: Module Temperature Warning 0: off 1: open LED Thousands: Motor Temperature Warning 0: off 1: open	0110	●	0xE35
F14.54	Current phase sequence	0: None 1: Forward 2: Reverse	0	×	0xE36
F14.55	Phase detection voltage	0~999.9V	0V	×	0xE37
F14.56	Pressure control proportional gain KP	0.00~10.00	2.00	●	0xE38
F14.57	Pressure control integral gain KI	0.00~10.00	5.00	●	0xE39
F14.58	Pressure filtering	0.00~50.000S	0.100S	●	0xE3A

F14.59	PID function setting	LED unit position: pressure nonlinear PI 0: On 1: Off LED ten: pressure PI lower limit 0:3/4 lower limit frequency 1:0 LED Hundreds: Reserved LED Thousands: Reserved	0110	●	0xE3B
F14.60	Reserved			●	0xE3C
F14.61	Temperature control proportional gain KP	0.00~10.00	2.00	●	0xE3D
F14.62	Temperature control integral gain KI	0.00~10.00	1.00	●	0xE3E
F14.63	PT temperature filter	0.00~50.00S	1.00S	●	0xE3F
F14.64	PK temperature filtering	0.00~50.00S	1.00S	●	0xE40
F14.65	Reserved			●	0xE41
FE.66	Fan frequency conversion power	According to the model settings		※	0xE42
FE.67	Modify parameter address	0~0xFFFF	0xFFFF	●	0xE43
FE.68	Modify parameter values	0~65535	0	●	0xE44
F14.69	Fan control parameters	LED unit position: oil cooling fan control 0: Auto 1: Manual LED ten: oil cooling fan operation 0: Stop 1: Run LED Hundreds: Motor Fan Control 0: automatic operation 1: forced operation LED Thousands: Reserved	0000	●	0xE45
F14.70	Fan setting frequency	0.00~300.00Hz	25.00Hz	※	0xE46
F14.71	Fan lower limit frequency	0.00~50.00Hz	15.00Hz	※	0xE47
F14.72	Fan acceleration time	0.00~600.00	20.00S	※	0xE48

F14.73	Fan deceleration time	0.00~600.00	20.00S	※	0xE49
F14.74	Fan carrier	1.0~10.0Khz	4.0Khz	※	0xE4A
F14.75	Fan motor rated frequency	0.00~300.00Hz	50.00hz	※	0xE4B
F14.76	Fan motor rated voltage	0~1500V	380v	※	0xE4C
F14.77	Fan motor rated current	0~100.0A	3.0A	※	0xE4D
F14.78	Fan motor rated	0~5000RPM	1450RPM	※	0xE4E
F14.79	Reserved				0xE4F
F14.80	Reserved				0xE50
F14.81	Consumables maintenance timeout shutdown setting	0~3000h(0 means no effect)	0h	●	0xE51
F14.82	Warning time	0~3000h(0 means no effect)	0h	●	0xE52
F14.83	Minimum frequency delay	0~5000S(0 means no effect)	0S	●	0xE53
F14.84	Pressure correction factor	50%-200%	100%	●	0xE54
F14.85	Inverter overvoltage point	0.0~600.0V(0 means no effect)	0V	●	0xE55
F14.86	Inverter undervoltage point	0.0~600.0V(0 means no effect)	0V	●	0xE56
F14.87	Reserved				0xE57
F14.88	Reserved				0xE58
F14.89	Reserved				0xE59
F14.87-F14.99	Reserved			●	

Terminal input and output function selection Terminal input and output function selection

X definition	Functional interpretation	X definition	Functional interpretation	X definition	Functional interpretation
0	No function	34	Suspension acceleration	80	External phase sequence error
1	Forward running	35-43	Reserved	81	Oil cooling fan overload
2	Reverse run	44	DC brake	82	Main motor over

			command		temperature
3	Three-wire operation (Xi)	45	Pre-excitation command terminal	83	Oil filter plug
4	Forward turn	46	Motor selection terminal	84	Oil blockage
5	Reverse jog	47-51	Reserved	85	Air filter blockage
6	Free parking	52	Run prohibition	86	Oil pump motor overload
7	emergency pull over	53	Forward prohibition	87	Main motor fan overload
8	Fault reset	54	Reverse prohibition		
9	External fault input	55-79	Reserved		
10-31	Reserved	46	Motor selection terminal		
32	Acceleration/deceleration time selection terminal 1	48-51	Reserved		
33	Acceleration/deceleration time selection terminal 2	52	Run prohibition		
Y/ Relay	Functional interpretation	Y/ Relay	Functional interpretation	Y/ Relay	Functional interpretation
0	no output	10	Output frequency level check 2 (FDT2)	40	load
1	The inverter is running	11	Arrived at a given frequency	41	Oil cooling fan
2	Inverter reverse	12	Zero speed operation	42	Motor fan
3	The inverter is turning in the middle	13	Upper limit frequency arrival	43	Oil pump
4	Fault trip alarm 1 (alarm during fault self-recovery)	14	Lower limit frequency arrival	44	Cold dryer
5	Fault trip alarm 2 (no alarm during fault self-recovery)	15-26	Reserved		
6	External downtime	27	Load pre-alarm output 1		
7	Inverter undervoltage	28	Load pre-alarm output 2		
8	The inverter is ready for operation	29	Motor overload pre-alarm		
9	Output frequency level	30-39	Reserved		

	detection 1 (FDT1)				
--	--------------------	--	--	--	--

Monitor Code

Access 'C' parameter group by pressing 'PRG' for more than 2s; check the current state of VFD

1. C00-Basic Parameter Monitor Group:

Function code	Function name	Unit and definition	Address	Function Code	Function name	Unit and definition	Address
C00.00	Given frequency	0.01Hz	0x2100	C00.20	Analog output AO1	0.01V/0.01mA/0.01kHz	0x2114
C00.01	Output frequency	0.01Hz	0x2101	C00.21	Analog output AO2(extend)	0.01V/0.01mA/0.01kHz	0x2115
C00.02	Output current	0.1A	0x2102	C00.22	Counting value of counter		0x2116
C00.03	Input voltage	0.1V	0x2103	C00.23	Running time after power on	0.1 hour	0x2117
C00.04	Output voltage	0.1V	0x2104	C00.24	Local accumulative running time	hour	0x2118
C00.05	Machine speed	1RPM	0x2105	C00.25	VFD power level	kW	0x2119
C00.06	Given torque	0.1%	0x2106	C00.26	VFD rated voltage	V	0x211A
C00.07	Output torque	0.1%	0x2107	C00.27	VFD rated current	A	0x211B
C00.08	PID given value	0.1%	0x2108	C00.28	Software version		0x211C
C00.09	PID feedback value	0.1%	0x2109	C00.29	PG feedback frequency	0.01Hz	0x211D
C00.10	Output power	0.1%	0x210A	C00.30	Counted time of timer	sec/min/hour	0x211E
C00.11	Bus voltage	0.1V	0x210B	C00.31	PID output value	0.00%	0x211F
C00.12	Module temperature 1	0.1℃	0x210C	C00.32	Software sub-version		0x2120
C00.13	Module temperature 2	0.1℃	0x210D	C00.33	Encoder angle	0.1°	0x2121
C00.14	Input terminal X on state	See input terminal diagram	0x210E	C00.34	Encoder deviation accumulative	1	0x2122
C00.15	Output terminal Y on state	See output terminal diagram	0x210F	C00.35	Encoder Z signal pulse count	1	0x2123

C00.16	Analog AI1 input value	0.001V/0.001mA	0x2110	C00.36	Fault pre alarm code	1	0x2124
C00.17	Analog AI2 input value	0.001V/0.001mA	0x2111	C00.37	Total power consumption (low bit)	1°	0x2125
C00.18	Reserved		0x2112	C00.38	Total power consumption (high bit)	10000°	0x2126
C00.19	Pulse input value of PUL port	0.001kHz	0x2113	C00.39	Power factor angle	1°	0x2127

2. C01-Malfunction Diagnosis Monitor Group

Function code	Function name	Unit and definition	Address
C01.00	Malfunction types	See fault code table	0x2200
C01.01	Malfunction diagnosis information	See fault code table	0x2201
C01.02	Malfunction running frequency	0.00~Max frequency	0x2202
C01.03	Malfunction output Voltage	0~1500V	0x2203
C01.04	Malfunction out Current	0.1~1000.0A	0x2204
C01.05	Malfunction Bus Voltage	0~3000V	0x2205
C01.06	Malfunction module temperature	0~100℃	0x2206
C01.07	Malfunction machine state	LED "0" digit: Running direction 0: FWD 1: REV LED "00" digit: Running status 0: Stop 1: ACC 2: DEC 3: Constant speed LED "000" digit: Reserved LED "0000" digit: Reserved	0x2207
C01.08	Malfunction input terminal status	See input terminal chart	0x2208
C01.09	Malfunction output terminal status	See output terminal chart	0x2209
C01.10	The last malfunction types	Please see malfunction code table	0x220A
C01.11	The first diagnosis information	Please see malfunction code table	0x220B
C01.12	The last malfunction running frequency	0.00~Maxfrequency	0x220C
C01.13	The last malfunction output voltage	0~1500V	0x220D
C01.14	The last malfunction output current	0.1~2000.0A	0x220E

C01.15	The last malfunction bus voltage	0~3000V	0x220F
C01.16	The last malfunction module temperature	0~100℃	0x2210
C01.17	The last malfunction machine state	LED "0" digit: Running direction 0: FWD 1: REV LED "00" digit: Running status 0: Stop 1: Constant speed 2: ACC 3: DEC LED "000" digit: Reserved LED "0000" digit: Reserved	0x2211
C01.18	The last malfunction input terminal state	See input terminal chart	0x2212
C01.19	The last malfunction output terminal state	See output terminal chart	0x2213
C01.20	The first two malfunction types	Please see malfunction information code table	0x2214
C01.21	The first two diagnosis information		0x2215
C01.22	The first three malfunction types		0x2216
C01.23	The first three diagnosis information		0x2217

Fault code table

Keyboard display	code	Fault type	Keyboard display	code	Fault type	Keyboard display	code	Fault type
	1	System exception		4	Overcurrent in acceleration		5	Deceleration over current
	6	Constant speed overcurrent		7	Accelerated overvoltage		8	Overpressure during deceleration
	9	Constant speed overpressure		10	Undervoltage in operation		11	Motor overload
	12	Inverter overload		13/65	Input phase missing phase		14	Output phase missing

					(alarm/warning)			
	15	Rectifier bridge overheating		16	Inverter overheating		17	External fault of the inverter
 	18/74	Rs485 communication error		19	Current detection fault		20	Motor detection failure
 	21/69	Storage failure		25	Motor detection failure		26	Parameter copy exception
	27	PG card connection error (alarm/warning)		28	Overpressure during shutdown		/	Keyboard communication failure
	30	Reserved		31	Initial position angle learning failed	 	32/70	Speed deviation is too large (alarm/warning)
 	33/71	Speed protection	 	34/67	Load protection 1	 	35/68	Load protection 2
	36	CPU timeout		37	OTPverification failure		38	Synchronous machine out of
	64	Low downtime		72	GPS machine lock		73	GPS disconnection
 	41/76	Motor overheating		39	Short circuit to ground		40	Fan short circuit

Air compressor fault subcode:

error code	Fault interpretation	error code	Fault interpretation	error code	Fault interpretation
3001	External phase sequence error	3011	Lubricant maintenance	3021	Module temperature is high
3002	Oil cooling fan overload	3012	Grease maintenance	3022	Main motor temperature is high(temperature detection)
3003	Main motor overheating (external terminal)	3013	Belt maintenance	3023	Motor fan overload
3004	Frequency conversion fault	3014	Pressure sensor failure	3024	Internal phase sequence failure

3005	Excessive pressure	3015	Reserved	3025	Reserved
3006	Oil temperature is too	3016	Oil filter failure	3026	Reserved
3007	Oil temperature is too low	3017	Oil and gas separator failure	3027	Reserved
3008	Oil filter maintenance	3018	Air filter failure	3028	Reserved
3009	Oil maintenance	3019	Arrears	3029	Reserved
3010	Air filter maintenance	3020	Oil pump overload	3030	Reserved

C04-Air compressor application monitoring group

Function code	Function code	Unit and definition	address
C04.00	Gas supply pressure	0.01Mpa	0x2500
C04.01	Exhaust gas temperature	1°C	0x2501
C04.02	Motor temperature	1°C	0x2502
C04.03	Machine state	0: Stop 1: No load 2: Load 3: Sleep	0x2503
C04.04	Air compressor status		0x2504
C04.05	Countdown information	1Sec	0x2505
C04.06	Image display		0x2506
C04.07	Alarm information		0x2507
C04.08	Set pressure	0.01Mpa	0x2508
C04.09	Fan speed	1RPM	0x2509

Function code	Function code	Unit and definition	address
C04.10	Fan frequency conversion frequency	0.01Hz	0x250A
C04.11	Fan current	0.1A	0x250B
C04.12	Fan current failure	----	0x250C
C04.13	Fan frequency conversion temperature	0.1°C	0x250D
C04.14	Fan program version	----	0x250E
C04.15	Current power consumption	1kWh	0x250F
C04.16	Total running time	Min	0x2510
C04.17	Total running time seconds	Sec	0x2511
C04.18	Total load time	Min	0x2512
C04.19	Total load time seconds	Sec	0x2513

5 debugging guidance

This chapter mainly introduces the field installation wiring and touch screen debugging process and analysis.

5.1 Installation wiring diagram

5.1.1 Main power cable

According to the following figure, the main power cable connection is required. The main motor input and output wiring and the oil temperature fan wiring are required to be grounded.

The main circuit wiring of the AP100 series air compressor is shown in the following figure:

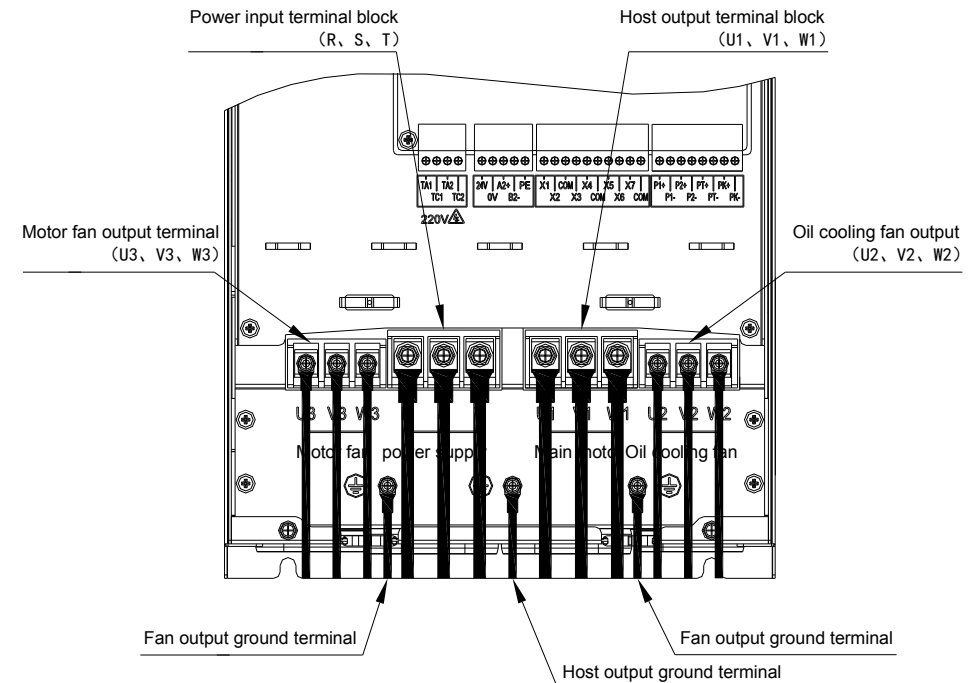

Figure 5-1: Main circuit wiring diagram

The main power cable selection requirements of AP100 series air compressors are as follows:

Drive model	Rated input current (A)	Input voltage, main motor cable (mm ²)	Oil temperature fan, output power cable (mm ²)	Input voltage, main motor terminal screw type	Oil temperature fan, output power terminal screw type	Ground terminal screw type
AP100-T3-7R5S	17	6	0.75	M5	M5	M5
AP100-T3-011S	25	10	0.75	M5	M5	M5
AP100-T3-015S	32	10	0.75	M6	M4	M6
AP100-T3-018K/S	38	16	0.75	M6	M4	M6
AP100-T3-022K/S	45	16	0.75	M6	M4	M6
AP100-T3-030K/S	60	25	0.75	M8	M4	M8
AP100-T3-037K/S	75	25	0.75	M8	M4	M8
AP100-T3-045K	90	35	0.75	M8	M4	M8
AP100-T3-055K	110	35	0.75	M8	M4	M8
AP100-T3-075K	150	50	0.75	M8	M4	M8

5.1.2 Control Terminal Cable

Connect the control terminal cable separately from the main power cable to ensure that the wiring is secure and reliable.

The control terminal wiring of AP100 air compressor is as shown below:

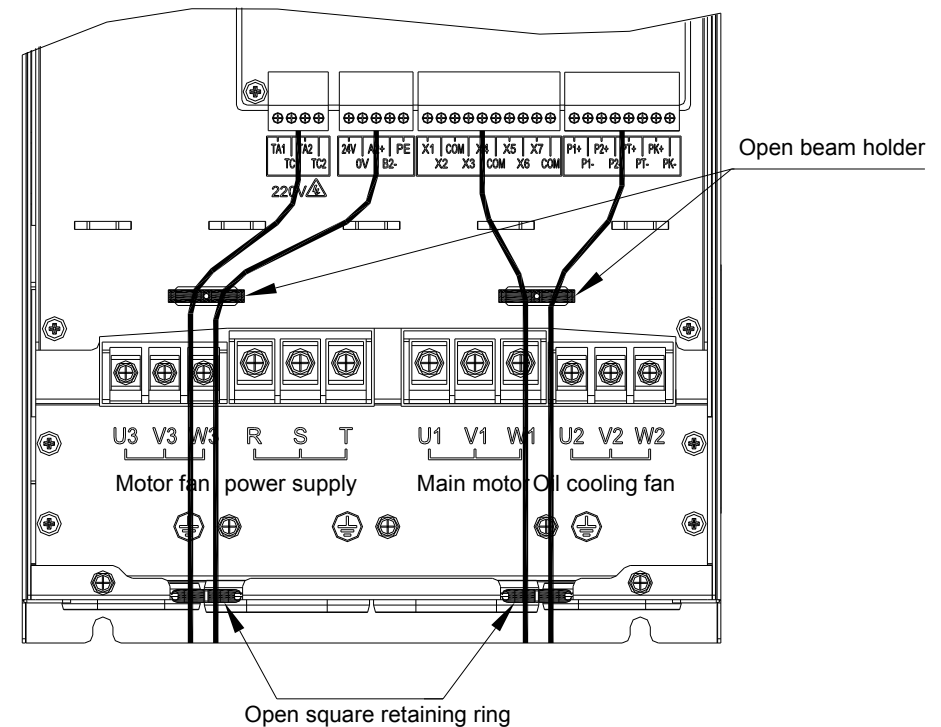

Figure 5-2: Wiring diagram of the control terminal

5.2 Touch screen debugging case analysis

The AP100 driver parameter debugging part is all completed on the touch screen. For detailed operation of the touch screen, please refer to Chapter 3, Touch Screen Display and Operation. The following only describes the parts related to driver debugging.

5.2.1 Frequency conversion debugging

Go to Menu > Frequency Debugging and the touch screen will display the frequency conversion debugging interface. Please follow the interface input parameters to complete the debugging of the host driver and fan driver step by step.

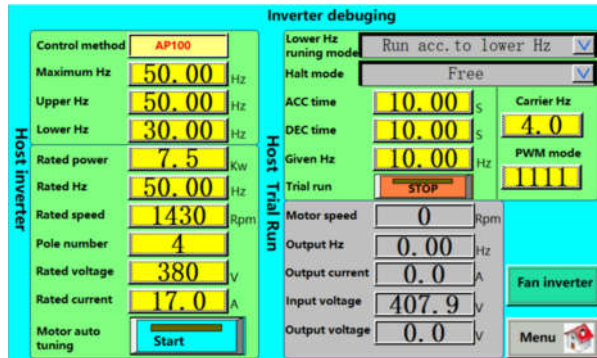

Figure 5-3: Frequency conversion debugging

5.2.2 Host motor parameter setting

Click menu -> frequency conversion debugging, the main motor parameter setting and self-learning are displayed on the left side of the touch screen.

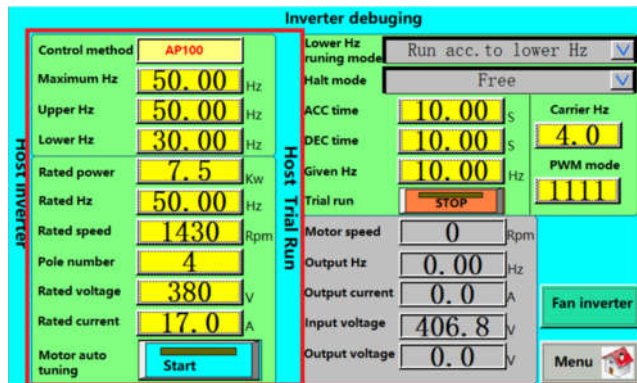

Figure 5-4: Main Motor - Motor Parameter Settings

Take the synchronous motor as an air compressor and set the motor parameters as an example.

(1) Input motor parameters: Select the control mode as open-loop permanent magnet air compressor, please input the rated power, rated frequency, rated speed, rated voltage and rated current on the motor nameplate. (The number of motor poles does not need to be input, the system will calculate according to the rated frequency and rated speed)

(2) Motor self-learning: After confirming that the motor parameter input is correct, press the motor self-learning button, the driver starts self-learning, and the learning is completed after about 10 seconds. If the travel abnormality occurs during the learning process, the motor self-learning button is clicked and the motor self-learning is immediately stopped.

5.2.3 Host motor trial run

After the learning is completed, on the right side of the above screen is the test run interface.

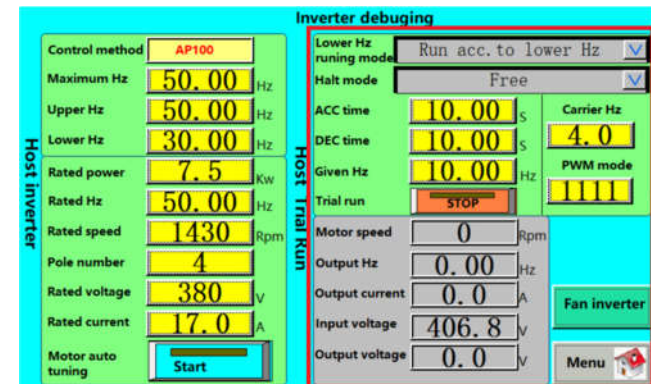

Figure 5-5: Main motor - commissioning.

(1) Determine the motor steering: set the "given frequency" to 10Hz and the lower limit frequency to 0. Click the trial run button to check whether the motor running direction is correct. If it is not correct, please click the trial run button to stop the motor and then the motor. Any two phases of the line are exchanged.

(2) Motor trial run: set "given frequency" to run to half of the rated frequency and rated frequency, check whether the motor is running normally, then set the upper/lower limit frequency, lower limit frequency operation mode, stop mode, etc.

5.2.4 Parameter setting of fan driver

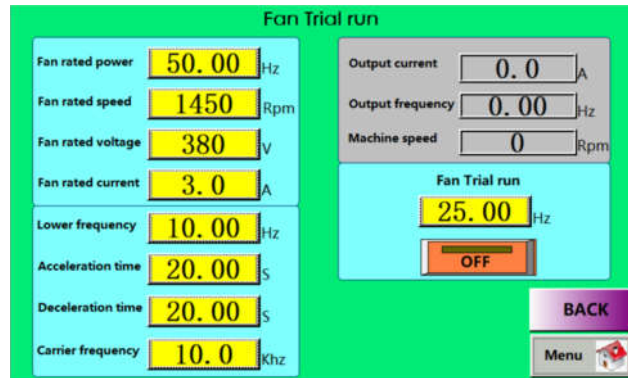

Figure 5-7: Fan - Parameter Settings

The fan parameters are the dual-inverter fan driver parameter settings, the single-conversion only shows the trial run button, and other parameters are not displayed. Enter the nameplate parameter of the fan motor into the fan parameter. Set the "Test run frequency setting" to 25Hz. Click the button in the test run box to see if the fan direction is correct. If it is not correct, please stop the fan phase sequence after stopping. Set the "Test Run Frequency Setting" to 50Hz to check whether the fan current is running normally. This interface can also observe the current, frequency and running speed of the oil cooling fan.

6 . Quality Assurance

6.1 Warranty period and scope

6.1.1 Warranty period

From the date of purchase of this product, users can enjoy the following three packages due to product quality issues:

- Retirement, replacement, and repair within 30 days after shipment;
- Replacement and repair within 90 days after shipment;
- Repair within 18 months after shipment;
- Except when exporting abroad;

6.1.2 Guaranteed range

Installation and commissioning: Installation and commissioning are implemented by the user in principle, and the company provides relevant technical support services. However, at the request of your company, the company or the company's service outlets can provide installation and commissioning services for a fee.

On-site diagnosis: Installation diagnosis is implemented by the user in principle, and the company provides relevant technical support services. However, at the request of your company, the company or the company's service network can provide on-site diagnostic services at a charge, and according to the diagnosis results, it is a free service that confirms the responsibility of the company.

Fault repair: For faulty products, products that are genuine product quality and under warranty, the company provides free repair service; but in the following cases, even if the equipment is still under warranty, the related services are covered by paid repair services. .

- Product failure caused by improper storage and use by the customer;
- Product failure caused by unauthorized modification and disassembly without the permission of the company;
- Product failure caused by the use range allowed by this product;
- Products that exceed the warranty period;
- Product failure caused by natural causes.

6.2 Liability exemption

Due to the failure of the company's products, the company only bears the corresponding responsibilities according to the terms stipulated in the warranty period and the scope of the guarantee. If the user needs more responsibility,

please insure the insurance company for the corresponding commercial insurance. Other extension losses caused by the failure of this product are not covered by the company.

For the following cases, whether within the guarantee period or not, it is not within the scope of the company's guarantee. If the user has the service demand, it belongs to the paid maintenance service.

- Product failure caused by improper storage and use by the customer;
- Product failure caused by unauthorized modification and disassembly without the permission of the company;
- Product failure caused by the use range allowed by this product;
- Products that exceed the warranty period;
- Product failure caused by natural causes;
- The company's payment was not paid as required by the contract.

6.3 Product Scope

- This product is not designed and manufactured for use in equipment that is used in a life-critical situation.
- If you need to use this product for special purposes such as manned mobile, medical, aerospace, nuclear power, electric power, submarine relay communication equipment or systems, please contact our sales department and use it without permission. Our company is not responsible for any accidents.
- This product is manufactured under strict quality control, but there is no guarantee that this product will never malfunction. If the user has more security requirements and reliability requirements, configure the backup device. If the user has more guarantees and requirements, please apply for the corresponding commercial insurance.